

SNMP MIBs to manage G.698 parameters

draft-galimbe-kunze-g-698-2-snmp-mib-00.txt

Gabriele Galimberti
Ruediger Kunze

Cisco
Deutsche Telekom

From Prague meeting

- Seek the ITU-T feedbacks
- Rename the document:
 - From: draft-galimbe-kunze-black-link-snmp-mib-00
 - To: draft-galimbe-kunze-g-698-2-snmp-mib-00
- Support the proposal done in “ Framework for Management and Control of Optical Interfaces supporting G.698.2” R.Kunze

Problem statement

- ITU-T G.698.2 defines the optical parameter to operate a DWDM system
- G.698.2 doesn't tell us how to manage it
- G.698.2 doesn't tell us how to code the parameters
- ITU-T agrees to define an SNMP MIB

More:

- **New technology availability:**
 - Tuneable DWDM interfaces in Routers / OTN / MPLS-TP clients
 - Colourless/Directionless/Contentionless ROADMs
- **New requirements**
 - Client equipments connected to ROADM (no more TXP)
 - Automatic Optical Path set-up
 - DWDM needs to know Transceivers parameters
 - Optical Transceivers parameters need to be provisioned/shared between Clients and DWDM
 - Interworking between third party systems: Router \leftrightarrow DWDM \leftrightarrow Router

G.698.2 reference network topology

(example)

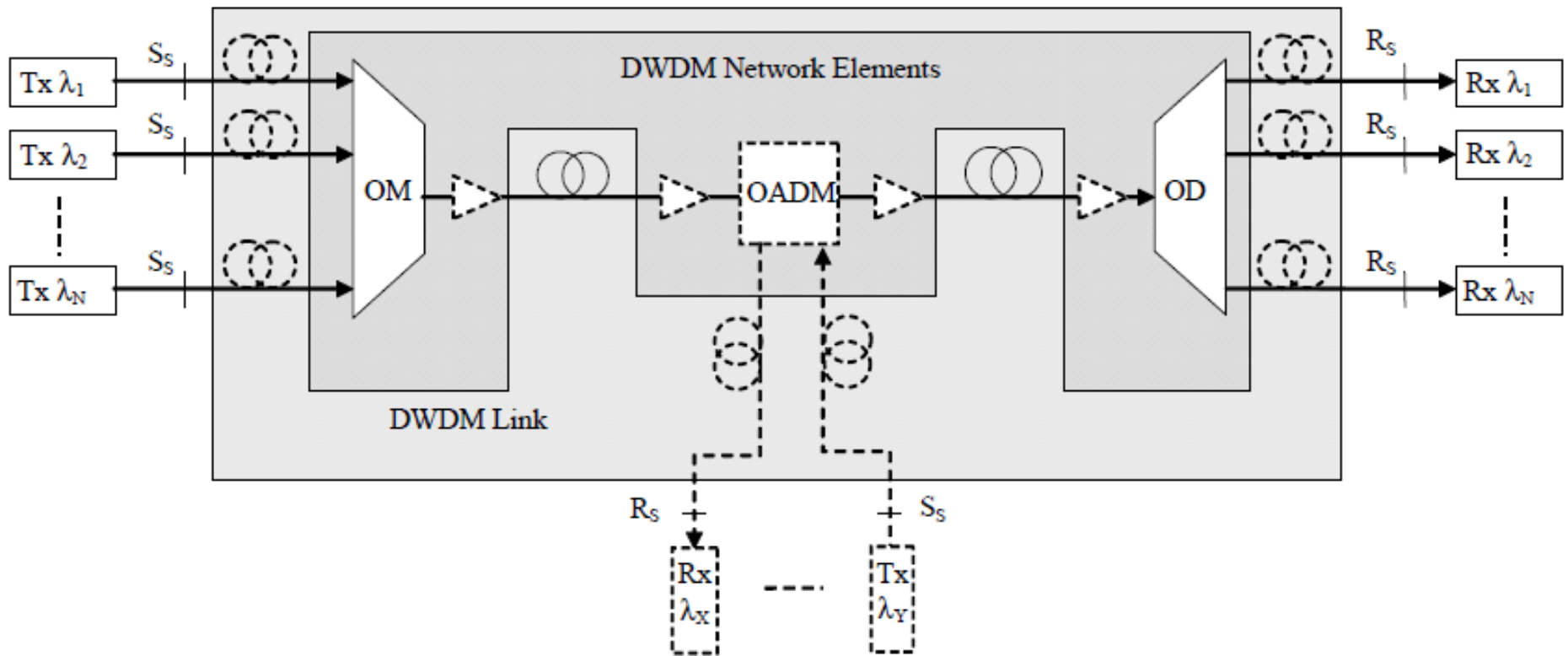

RFC-3591 SNMP MIB as starting point

- RFC-3591 specifies the SNMP MIB of some optical parameters.
- We need an extensions to Managed Objects for the Optical Interface Type to support all the Optical Parameters proposed by ITU-T G.698.2 and its future extensions (like 40Gbs and 100GBs)
- **Working group ?**

Example (details in draft)

Parameter	Unit	G.698.2	Managed Parameters (SNMP)	SET/GET/Trap	Notes
General information					
Minimum channel spacing	GHz	X	X	GET	
Bit rate/line coding of optical tributary signals					
Frequency (bandwidth) (2.5G, 10G, 40G, 100G, ...)	GHz	2.5 - 10G	2.5-10-40-100G	GET/SET	SET for 10G bitrate
Modulation Format		X	X	GET	
Coding (NRZ, RZ, PAM, PM,)		X			
Maximum bit error ratio		X			for discussion
Fibre type		X			for discussion
FEC Coding		X	X	GET/SET	e.g. GFEC, EFEC
Wavelength Range		X	X	GET	min max wavelength spectrum
Wavelength Grid (GHz. 100, 50, 25, ...)					
Wavelength Value (see G.694.1)		X(G.694)	X	GET/SET	
Tranciver Class			X	GET	

Parameter	Unit	G.698.2	Managed Parameters (SNMP)	SET/GET/Trap	Notes
Alarms					
Threshold Crossing Alert (TCA - Alarm)			rfc3591	G / T	See Performance Monitoring TCA
Laser Bias Current (%)			x	G / T	
LOW-TXPOWER			rfc3591	G / T	
HIGH-TXPOWER			rfc3591	G / T	
LOW-RXPOWER			rfc3591	G / T	
HIGH-RXPOWER			rfc3591	G / T	
OTUk-LOF or more generic LOF			rfc3591	G / T	
Forward Defect Indication (FDI)			x	G / T	
Backward Error Indication (BEI)			x	G / T	
Backward Defect Indication (BDI)			rfc3591	G / T	
Trace Identifier Mismatch (tim)			rfc3591	G / T	
Signal Degrade (sd)			rfc3591	G / T	
Server Signal Failure (SSF)			rfc3591	G / T	
AIS			rfc3591	G / T	
Loss of Multiframe (lom)			rfc3591	G / T	

Next Steps

- Feedbacks on draft effectiveness
- Agree whether the Draft will be a RFC-3591 extension or a New Draft
- Work on parameter contents / extension and SNMP MIB structure
- Encourage co-authors and contributors