

SAVI Requirements and Solutions for IPv4/IPv6 Transition

draft-xu-savi-transition-00.txt

K.Xu, G.Hu, J.Bi, M.Xu
Tsinghua University

F.Shi
China Telecom

IETF 82, Taipei

November 2011

Current Network Situation

- ▶ Increasingly critical spoofing issue
- ▶ IPv4 exhaustion
- ▶ A long period for transition

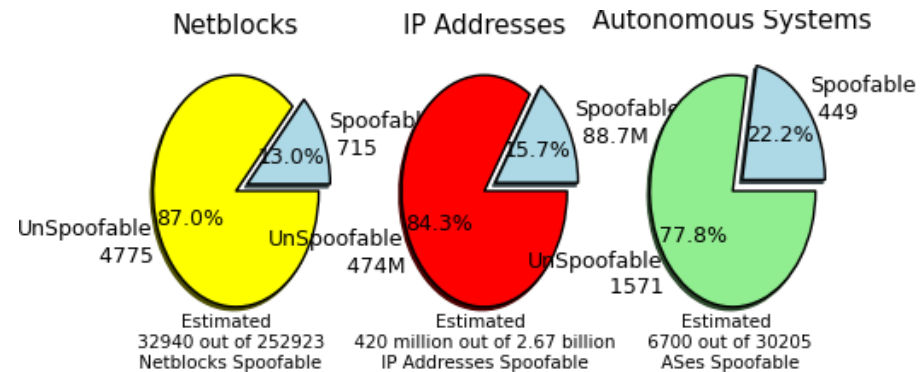

Spoofable netblocks, IP addresses and AS
From MIT spoofer project

RIR	Projected Exhaustion Date	Remaining Address (/8s)
APNIC:	19-Apr-2011	1.2052
RIPENCC:	27-Jun-2012	3.9161
ARIN:	06-Jun-2013	5.9107
LACNIC:	05-Mar-2014	4.2732
AFRINIC:	09-Jul-2014	4.3815

IPv4 Address Resources

From <http://www.potaroo.net/tools/ipv4/>

Requirements from SAVI Charter

- ▶ Preventing nodes attached to the same IP link from spoofing each other's IP addresses
 - ▶ IPv4 and IPv6 need to be covered
 - ▶ All address assignment mechanisms need to be supported (stateless, stateful, and manual)

 - ▶ But now, works in SAVI WG is only for IPv6 networks
 - ▶ SAVI should also consider spoofing in IPv4/IPv6 transition
- 

IPv4 over IPv6 Scenario

Hosts use IPv4

addresses to access
IPv4 Internet via the

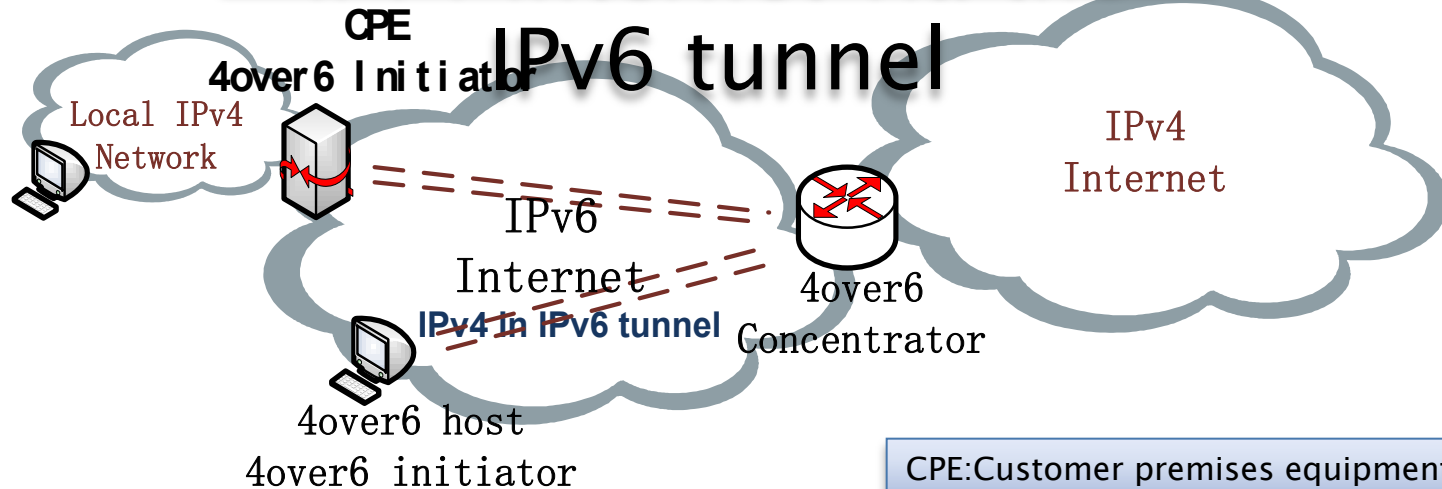

- Some hosts access both IPv4/IPv6 Internet via dual-stack
- Some hosts access IPv4 Internet via CPE proxy
- 4over6 has stateless and stateful working scenarios

Scenario 1: Dual-stack in stateless

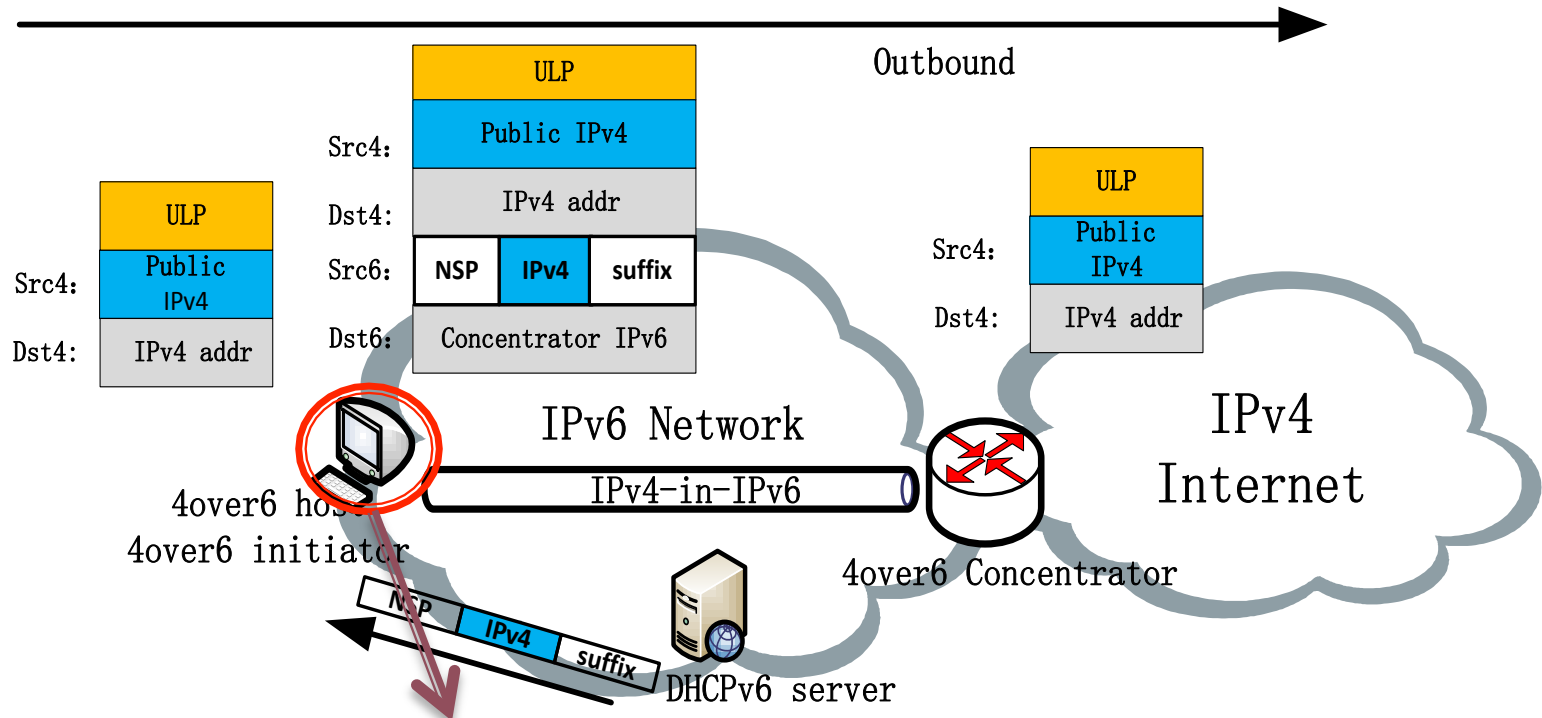

Accessing SAVI Switches for Dual-Stack Hosts

1.snooping DHCPv6

2.binding relationship: <IPv6、Switch-Port、MAC、**IPv4**>

Scenario 2: Dual-stack in stateful

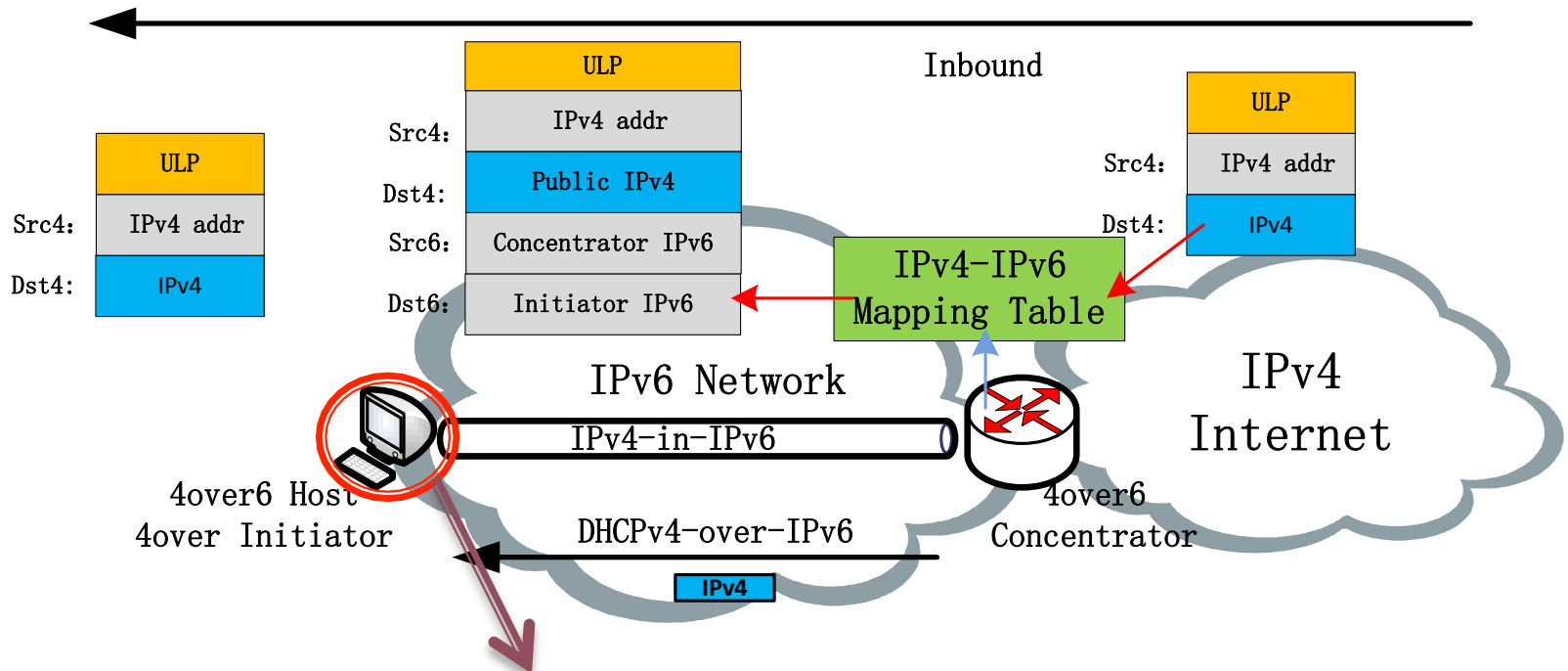

Accessing SAVI Switches for Dual-Stack Hosts

- 1. snooping DHCPv6 & **DHCPv4** (parse from tunnel)
- 2. binding relationship: <IPv6, Switch-Port, MAC, **IPv4**>

Scenario 3: CPE Proxy in stateless

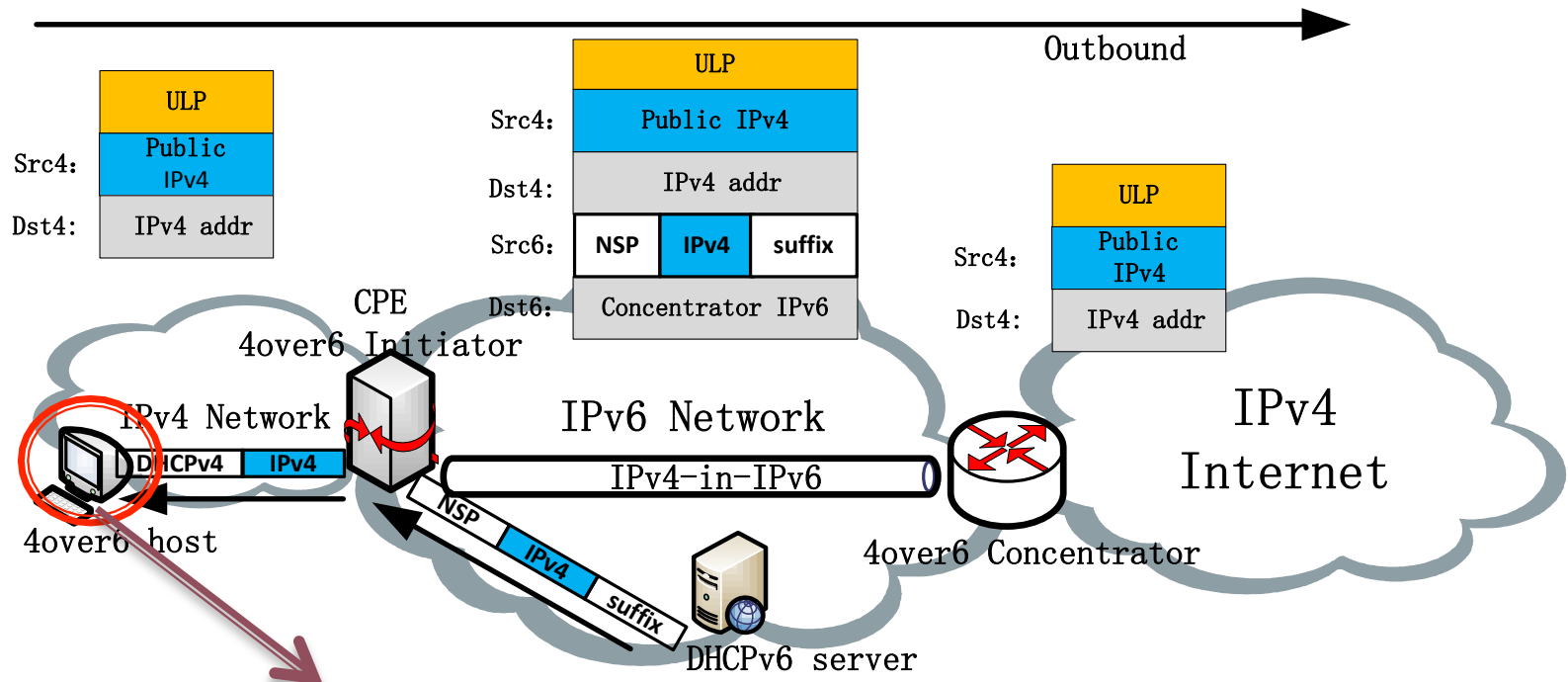

Accessing SAVI Switches for CPE behind Hosts

- 1.snooping **DHCPv4**
- 2.binding relationship: **<IPv4, Switch-Port, MAC>**

Scenario 4: CPE proxy in stateful

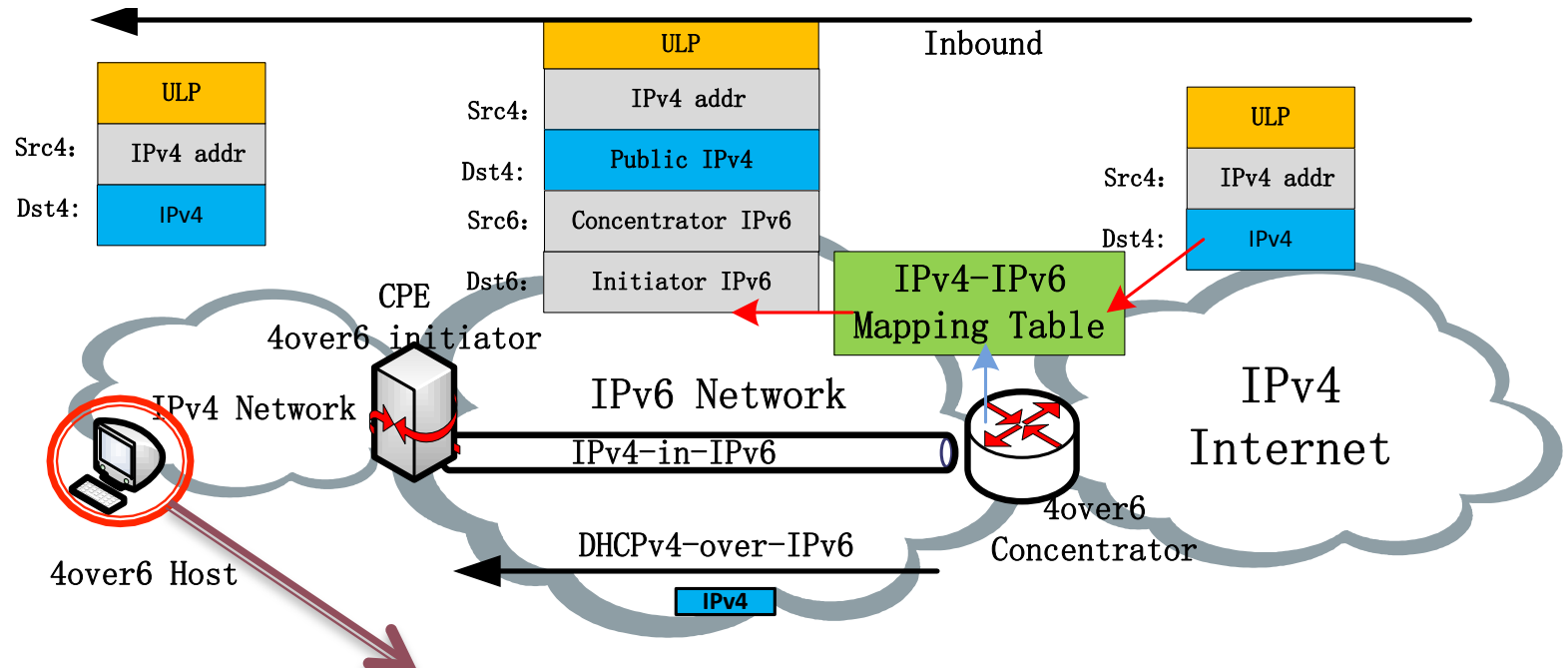

Accessing SAVI Switches for CPE behind Hosts

- 1.snooping **DHCPv4**
- 2.binding relationship: **<IPv4, Switch-Port, MAC>**

Conclusion

- ▶ IPv4 and IPv6 will co-exist for a long time.
- ▶ Source address validation should also be considered in IPv4/IPv6 transition

End

Please refer to our RFC draft:

[The Requirements and Tentative Solutions for SAVI in IPv4/IPv6 Transition](#)

Thanks!

