

DMM
Internet-Draft
Intended status: Informational
Expires: November 10, 2017

H. Chan, Ed.
X. Wei
Huawei Technologies
J. Lee
Sangmyung University
S. Jeon
Sungkyunkwan University
A. Petrescu
CEA, LIST
F. Templin
Boeing Research and Technology
May 9, 2017

Distributed Mobility Anchoring
draft-ietf-dmm-distributed-mobility-anchoring-05

Abstract

This document defines distributed mobility anchoring in terms of the different configurations, operations and parameters of mobility functions to provide different IP mobility support for the diverse mobility needs in 5G Wireless and beyond. A network or network slice may be configured with distributed mobility anchoring functions according to the needs of mobility support. In the distributed mobility anchoring environment, multiple anchors are available for mid-session switching of an IP prefix anchor. To start a new flow or to handle a flow not requiring IP session continuity as a mobile node moves to a new network, the flow can be started or re-started using a new IP address configured from the new IP prefix which is anchored to the new network. For a flow requiring IP session continuity, the anchoring of the prior IP prefix may be moved to the new network. The mobility functions and their operations and parameters are general for different configurations. The mobility signaling may be between anchors and nodes in the network in a network-based mobility solution. It may also be between the anchors and the mobile node in a host-based solution. The mobile node may be a host, but may also be a router carrying a network requiring network mobility support.

Status of This Memo

This Internet-Draft is submitted in full conformance with the provisions of BCP 78 and BCP 79.

Internet-Drafts are working documents of the Internet Engineering Task Force (IETF). Note that other groups may also distribute working documents as Internet-Drafts. The list of current Internet-Drafts is at <http://datatracker.ietf.org/drafts/current/>.

Internet-Drafts are draft documents valid for a maximum of six months and may be updated, replaced, or obsoleted by other documents at any time. It is inappropriate to use Internet-Drafts as reference material or to cite them other than as "work in progress."

This Internet-Draft will expire on November 10, 2017.

Copyright Notice

Copyright (c) 2017 IETF Trust and the persons identified as the document authors. All rights reserved.

This document is subject to BCP 78 and the IETF Trust's Legal Provisions Relating to IETF Documents (<http://trustee.ietf.org/license-info>) in effect on the date of publication of this document. Please review these documents carefully, as they describe your rights and restrictions with respect to this document. Code Components extracted from this document must include Simplified BSD License text as described in Section 4.e of the Trust Legal Provisions and are provided without warranty as described in the Simplified BSD License.

Table of Contents

1.	Introduction	3
2.	Conventions and Terminology	5
3.	Distributed Mobility Anchoring	7
3.1.	Configurations for Different Networks or Network Slices .	7
3.1.1.	Network-based Mobility Support for a Flat Network . .	7
3.1.2.	Network-based Mobility Support for a Hierarchical Network	8
3.1.3.	Host-based Mobility Support	11
3.1.4.	NETwork MObility (NEMO) Basic Support	11
3.2.	Operations and Parameters	13
3.2.1.	Location Management	13
3.2.2.	Forwarding Management	16
4.	IP Mobility Handling in Distributed Anchoring Environments - Mobility Support Only When Needed	24
4.1.	No Need of IP Mobility: Changing to New IP Prefix/Address	24
4.1.1.	Guidelines for IPv6 Nodes: Changing to New IP Prefix/Address	26
4.2.	Need of IP Mobility	28
4.2.1.	Guidelines for IPv6 Nodes: Need of IP Mobility . . .	29
5.	IP Mobility Handling in Distributed Mobility Anchoring Environments - Anchor Switching to the New Network	31
5.1.	IP Prefix/Address Anchor Switching for Flat Network . . .	31
5.1.1.	Guidelines for IPv6 Nodes: Switching Anchor for Flat Network	32

5.2.	IP Prefix/Address Anchor Switching for Flat Network with Centralized Control Plane	34
5.2.1.	Additional Guidelines for IPv6 Nodes: Switching Anchor with Centralized CP	36
5.3.	Hierarchical Network	37
5.3.1.	Additional Guidelines for IPv6 Nodes: Hierarchical Network with No Anchor Relocation	39
5.4.	IP Prefix/Address Anchor Switching for a Hierarchical Network	39
5.4.1.	Additional Guidelines for IPv6 Nodes: Switching Anchor with Hierarchical Network	41
5.5.	Network Mobility	41
5.5.1.	Additional Guidelines for IPv6 Nodes: Network mobility	43
6.	Security Considerations	44
7.	IANA Considerations	45
8.	Contributors	45
9.	References	45
9.1.	Normative References	45
9.2.	Informative References	48
	Authors' Addresses	48

1. Introduction

A key requirement in distributed mobility management [RFC7333] is to enable traffic to avoid traversing a single mobility anchor far from an optimal route. The traffic of a flow SHOULD then be able to change from traversing one mobility anchor to traversing another mobility anchor as a mobile node (MN) moves, or when changing operation and management requirements call for mobility anchor switching, thus avoiding non-optimal routes.

Companion distributed mobility management documents are already addressing the architecture and deployment [I-D.ietf-dmm-deployment-models], source address selection [I-D.ietf-dmm-ondemand-mobility], and control-plane data-plane signaling [I-D.ietf-dmm-fpc-cpd]. Yet in 5G Wireless and beyond, the mobility requirements are diverse, and IP mobility support is no longer by default with a one-size-fit-all solution. In different networks or network slices [I-D.geng-netslices-architecture], different kinds of mobility support are possible depending on the needs. It may not always be obvious on how to best configure and use only the needed mobility functions to provide the specific mobility support. This draft defines different configurations, functional operations and parameters for distributed mobility anchoring and explains how to use them to make the route changes to avoid unnecessarily long routes.

Distributed mobility anchoring employs multiple anchors in the data plane. In general, control plane functions may be separate from data plane functions and be centralized but may also be co-located with the data plane functions at the distributed anchors. Different configurations of distributed mobility anchoring are described in Section 3.1. For instance, the configurations for network-based mobility support in a flat network, for network-based mobility support in a hierarchical network, for host-based mobility support, and for Network MObility (NEMO) basic support are described respectively in Section 3.1.1, Section 3.1.2, Section 3.1.3 and Section 3.1.4. Required operations and parameters for distributed mobility anchoring are presented in Section 3.2. For instance, location management is described in Section 3.2.1, forwarding management is described in Section 3.2.2.

As an MN attaches to an access router and establishes a link between them, a /64 IPv6 prefix anchored to the router may be assigned to the link for exclusive use by the MN [RFC6459]. The MN may then configure a global IPv6 address from this prefix and use it as the source IP address in a flow to communicate with its correspondent node (CN). When there are multiple mobility anchors, an address selection for a given flow is first required before the flow is initiated. Using an anchor in an MN's network of attachment has the advantage that the packets can simply be forwarded according to the forwarding table. However, after the flow has been initiated, the MN may later move to another network, so that the IP address no longer belongs to the current network of attachment of the MN.

Whether the flow needs IP session continuity will determine how to ensure that the IP address of the flow will be anchored to the new network of attachment. If the ongoing IP flow can cope with an IP prefix/address change, the flow can be reinitiated with a new IP address anchored in the new network as shown in Section 4.1. On the other hand, if the ongoing IP flow cannot cope with such change, mobility support is needed as shown in Section 4.2. A network or network slice supporting a mix of flows both requiring and not requiring IP mobility support will need to distinguish these flows. The guidelines for the network or network slice to make such a distinction are described in Section 4.1.1. The general guidelines for such network or network slice to provide IP mobility support are described in Section 4.2.1.

Specifically, IP mobility support can be provided by relocating the anchoring of the IP prefix/address of the flow from the home network of the flow to the new network of attachment. The basic case may be with network-based mobility for a flat network configuration described in Section 5.1 with the guidelines described in Section 5.1.1. This case is discussed further with a centralized

control plane in Section 5.2 with additional guidelines described in Section 5.2.1. A level of hierarchy of nodes may then be added to the network configuration. Mobility involving change in the Data Plane Node (DPN) without changing the Data Plane Anchor (DPA) is described in Section 5.3 with additional guidelines described in Section 5.3.1. Mobility involving change in the DPN without changing the DPA is described in Section 5.4 with additional guidelines described in Section 5.4.1.

2. Conventions and Terminology

The key words "MUST", "MUST NOT", "REQUIRED", "SHALL", "SHALL NOT", "SHOULD", "SHOULD NOT", "RECOMMENDED", "MAY", and "OPTIONAL" in this document are to be interpreted as described in [RFC2119].

All general mobility-related terms and their acronyms used in this document are to be interpreted as defined in the Mobile IPv6 (MIPv6) base specification [RFC6275], the Proxy Mobile IPv6 (PMIPv6) specification [RFC5213], the "Mobility Related Terminologies" [RFC3753], and the DMM current practices and gap analysis [RFC7429]. These include terms such as mobile node (MN), correspondent node (CN), home agent (HA), home address (HoA), care-of-address (CoA), local mobility anchor (LMA), and mobile access gateway (MAG).

In addition, this document uses the following terms:

Home network of an application session or a home address: the network that has assigned the HoA used as the session identifier by the application running in an MN. The MN may be running multiple application sessions, and each of these sessions can have a different home network.

IP prefix/address anchoring: An IP prefix, i.e., Home Network Prefix (HNP), or address, i.e., HoA, assigned for use by an MN is topologically anchored to an anchor node when the anchor node is able to advertise a connected route into the routing infrastructure for the assigned IP prefix.

Location Management (LM) function: managing and keeping track of the internetwork location of an MN. The location information may be a binding of the advertised IP address/prefix, e.g., HoA or HNP, to the IP routing address of the MN or of a node that can forward packets destined to the MN.

When the MN is a mobile router (MR) carrying a mobile network of mobile network nodes (MNN), the location information will also

include the mobile network prefix (MNP), which is the aggregate IP prefix delegated to the MR to assign IP prefixes for use by the MNs in the mobile network.

LM is a control plane function.

In a client-server protocol model, location query and update messages may be exchanged between a Location Management client (LMc) and a Location Management server (LMs).

Optionally, there may be a Location Management proxy (LMp) between LMc and LMs.

With separation of control plane and data plane, the LM function is in the control plane. It may be a logical function at the control plane node, control plane anchor, or mobility controller.

It may be distributed or centralized.

Forwarding Management (FM) function: packet interception and forwarding to/from the IP address/prefix assigned for use by the MN, based on the internetwork location information, either to the destination or to some other network element that knows how to forward the packets to their destination.

This function may be used to achieve traffic indirection. With separation of control plane and data plane, the FM function may split into a FM function in the data plane (FM-DP) and a FM function in the control plane (FM-CP).

FM-DP may be distributed with distributed mobility management. It may be a function in a data plane anchor or data plane node.

FM-CP may be distributed or centralized. It may be a function in a control plane node, control plane anchor or mobility controller.

Security Management (SM) function: The security management function controls security mechanisms/protocols providing access control, integrity, authentication, authorization, confidentiality, etc. for the control plane and data plane.

This function resides in all nodes such as control plane anchor, data plane anchor, mobile node, and correspondent node.

3. Distributed Mobility Anchoring

3.1. Configurations for Different Networks or Network Slices

The mobility functions may be implemented in different configurations of distributed mobility anchoring in architectures separating the control and data planes. The separation described in [I-D.ietf-dmm-deployment-models] has defined the home control plane anchor (Home-CPA), home data plane anchor (Home-DPA), access control plane node (Access-CPN), and access data plane node (Access-DPN), which are respectively abbreviated as CPA, DPA, CPN, and DPN here.

Different networks or different network slices may have different configurations in distributed mobility anchoring.

The configurations also differ depending on the desired mobility supports: network-based mobility support for a flat network in Section 3.1.1, network-based mobility support for a hierarchical network in Section 3.1.2, host-based mobility support in Section 3.1.3, and NETwork MObility (NEMO) based support in Section 3.1.4.

3.1.1. Network-based Mobility Support for a Flat Network

Figure 1 shows two different configurations of network-based distributed mobility management for a flat network.

The features common to both Figures 1(a) and 1(b) are:

- dmm:1 There are multiple instances of DPA, each with an FM-DP function.
- dmm:2 The control plane may either be distributed (not shown) or centralized. The CPA may co-locate with DPA or may separate. When the CPA, each with an FM-CP function, is co-located with the distributed DPA there will be multiple instances of the co-located CPA and DPA (not shown).
- dmm:3 An IP prefix/address IP_1 , which is anchored to the DPA with the IP prefix/address IP_{a1} , is assigned for use by AN MN. The MN uses IP_1 to communicate with a CN not shown in the figure. The flow of this communication session is shown as flow(IP_1 , ...), meaning it uses IP_1 and other parameters.

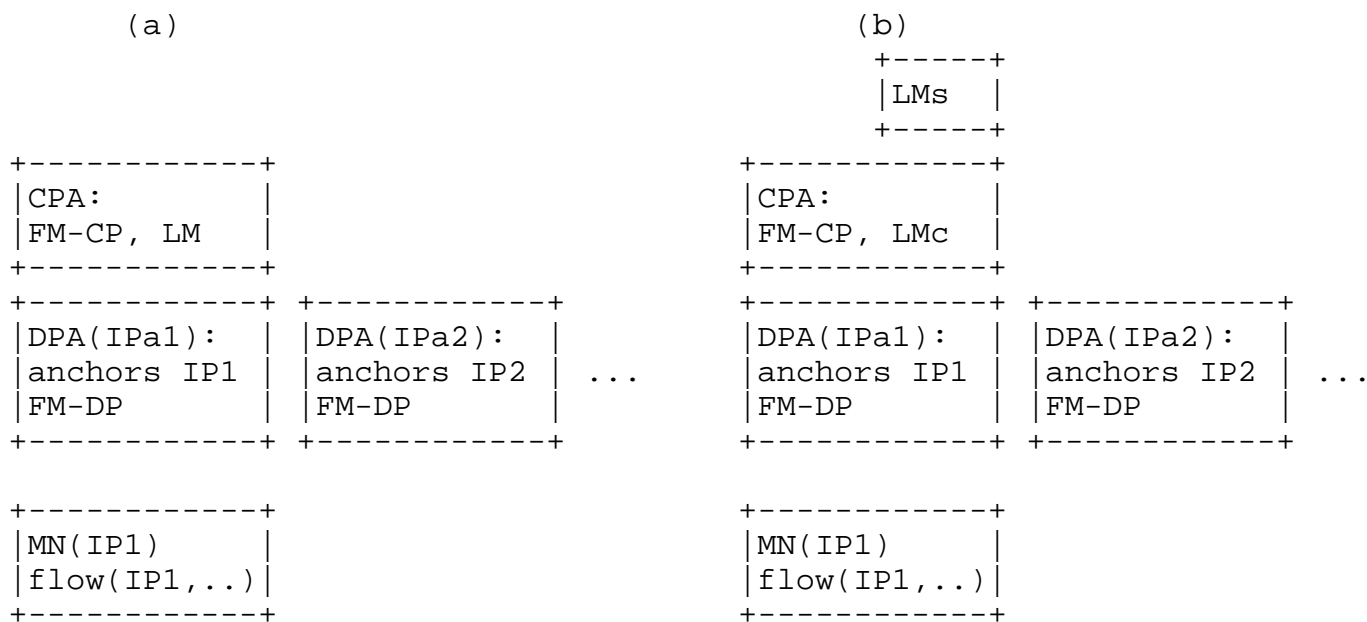

Figure 1. Configurations of network-based mobility management for a flat network (a) FM-CP and LM at CPA, FM-DP at DPA; (b) Separate LMs, FM-CP and LMc at CPA, FM-DP at DPA.

In Figure 1(a), LM is at the CPA. Then LM may be distributed or centralized according to whether the CPA is distributed (not shown) or centralized.

Figure 1(b) differs from Figure 1(a) in that the LM function is split into a separate server LMs and a client LMc at the CPA. Then, the LMs may be centralized whereas the LMc may be distributed or centralized according to whether the CPA is distributed (not shown) or centralized.

3.1.2. Network-based Mobility Support for a Hierarchical Network

Figure 2 shows two different configurations of network-based mobility management for a hierarchical network.

(a)

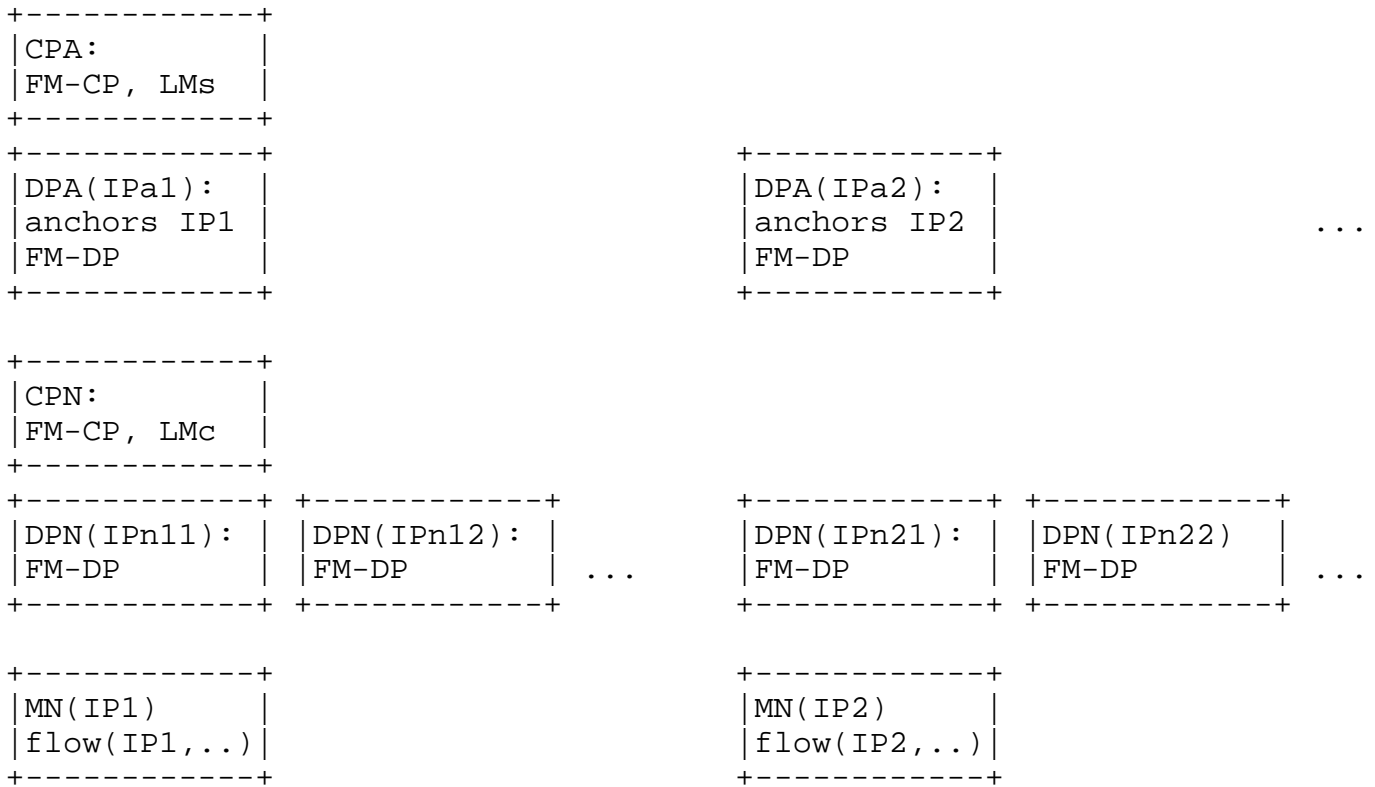

Figure 2(a). Configurations of network-based mobility management for a hierarchical network with FM-CP and LMs at CPA, FM-DP at DPA; FM-CP and LMc at CPN, FM-DP at DPN.

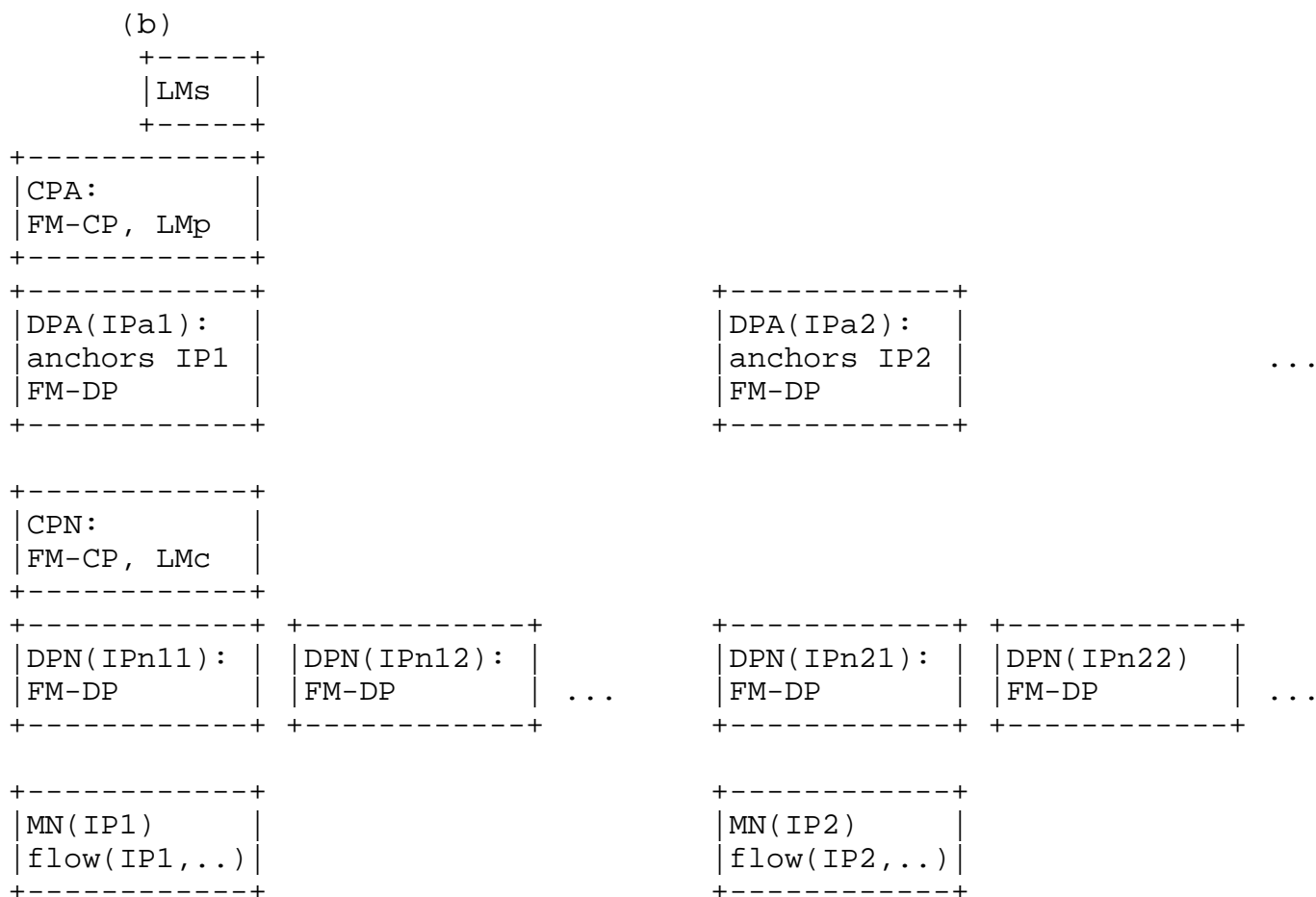

Figure 2(b). Configurations of network-based mobility management for a hierarchical network with separate LMs, FM-CP and LMp at CPA, FM-DP at DPA; FM-CP and LMc at CPN, FM-DP at DPN.

In addition to the dmm feature already described in Figure 1, Figure 2 shows that there may be multiple instances of DPN, each with an FM-DP function, for each DPA in the hierarchy. Also when the CPN, each with an FM-CP function, is co-located with the distributed DPN there will be multiple instances of the co-located CPN and DPN (not shown).

In Figure 2(a), LMs is at the CPA and LMc is at the CPN. Then, LMs may be distributed or centralized according to whether the CPA is distributed or centralized.

Figure 2(b) differs from Figure 2(a) in that the LMs is separated out, and a proxy LMp at the CPA is added between the separate LMs and LMc at the CPN. Then, LMs may be centralized whereas the LMp may be distributed or centralized according to whether the CPA is distributed or centralized.

3.1.3. Host-based Mobility Support

Host-based variants of the mobility function configurations from Figures 2(a) and 2(b) are respectively shown in Figures 3(a) and 3(b) where the role to perform mobility functions by CPN and DPN are now taken by the MN. The MN then needs to possess the mobility functions FM and LMc.

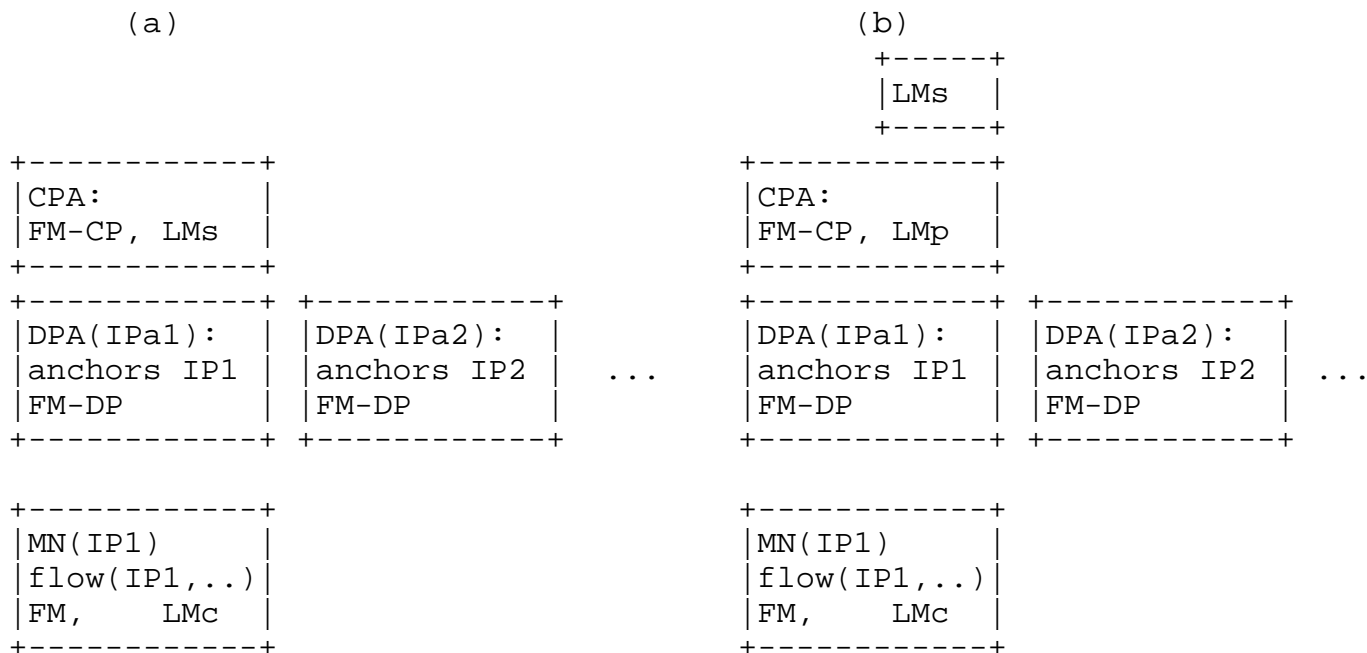

Figure 3. Configurations of host-based mobility management (a) FM-CP and LMs at CPA, FM-DP at DPA, FM and LMc at MN; (b) Separate LMs, FM-CP and LMp at CPA, FM-DP at DPA, FM and LMc at MN.

Figure 3 shows 2 configurations of host-based mobility management with multiple instances of DPA for a distributed mobility anchoring environment. Figures 3(a) and 3(b) can be obtained by simply collapsing CPN, DPN and MN from the respective Figures 2(a) and 2(b) into the MN in Figure 3 which now possesses the mobility functions FM and LMc that were performed previously by the CPN and the DPN.

3.1.4. Network MObility (NEMO) Basic Support

Figure 4 shows two configurations of NEMO basic support for a mobile router.

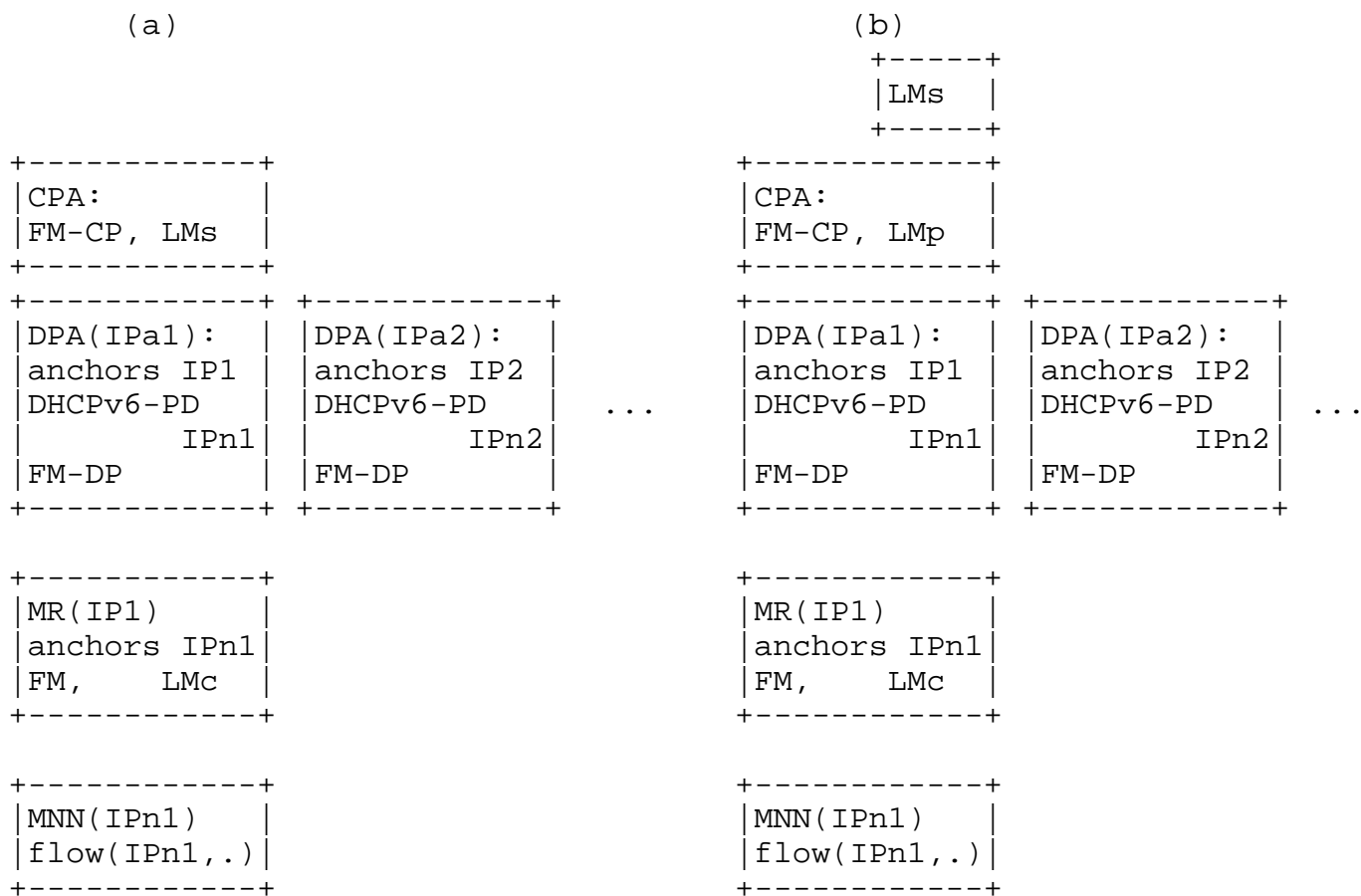

Figure 4. Configurations of NEMO basic support for a MR. (a) FM-CP and LMs at CPA, FM-DP at DPA, FM and LMc at MR; (b) Separate LMs, FM-CP and LMp at CPA, FM-DP at DPA, FM and LMc at MR.

Figure 4 shows 2 configurations of host-based mobility management for a MR with multiple instances of DPA for a distributed mobility anchoring environment. Figures 4(a) and 4(b) can be obtained by simply changing the MN from the respective Figures 3(a) and 3(b) into the MR carrying a mobile network consisting of mobile network nodes (MNNs) in Figure 4.

An IP prefix/address IPn1 anchored to the MR is assigned for use by the MNN in the mobile network. The MNN uses IPn1 to communicate with a correspondent node (CN) not shown in the figure. The flow of this communication session is shown as flow(IPn1, ..), meaning it uses IPn1 and other parameters.

To enable the MR to anchor and to assign the IP prefix IPn1, the DPA delegates the prefix using DHCPv6-PD to the MR.

3.2. Operations and Parameters

The operations of distributed mobility anchoring are defined in order that they might work together to produce a distributed mobility solution. The needed information is passed as mobility message parameters, which must be protected in terms of integrity. Some parameters may require a means to support privacy of an MN or MR.

The mobility needs in 5G Wireless and beyond are diverse. Therefore operations needed to enable different distributed mobility solutions in different distributed mobility anchoring configurations are extensive as illustrated below. It is however not necessary for every distributed mobility solution to exhibit all the operations listed in this section. A given distributed mobility solution may exhibit only those operations needed.

3.2.1. Location Management

An example LM design consists of a distributed database with multiple LMs servers. The location information about the prefix/address of an MN is primarily at a given LMs. Peer LMs may exchange the location information with each other. LMc may retrieve a given record or send a given record update to LMs.

Location management configurations:

LM-cfg: As shown in Section 3.1:

LMs may be implemented at CPA, may be co-located with LMc at CPA, or may be a separate server.

LMc may be at CPA, CPN, or MN.

LMp may proxy between LMs and LMc.

Specifically:

Location management operations and parameters:

LM-cfg:1 LMs may be co-located with LMc at CPA in a flat network with network-based mobility as shown in Figure 1(a) in Section 3.1.1.

LM-cfg:2 LMs may be a separate server whereas LMc is implemented in CPA in a flat network with network-based mobility as shown in Figure 1(b) in Section 3.1.1.

- LM-cfg:3 LMs may be implemented at CPA, whereas LMc is implemented at CPN in a hierarchical network with network-based mobility as shown in Figure 2(a) in Section 3.1.2, at MN for host-based mobility as shown in Figure 3(a) in Section 3.1.3, or at MR for network mobility as shown in Figure 4(a) in Section 3.1.4.
- LM-cfg:4 LMs may be a separate server with LMp implemented at CPA whereas LMc is implemented at CPN in a hierarchical network with network-based mobility as shown in Figure 2(b) in Section 3.1.2, at MN for host-based mobility as shown in Figure 3(b) in Section 3.1.3, or at MR for network mobility as shown in Figure 4(b) in Section 3.1.4.
- LM-db: LM may manage the location information in a client-server database system.

Example LM database functions are as follows:

- LM-db:1 LMc may query LMs about location information for a prefix of MN (pull).
Parameters:
- IP prefix of MN: integrity support required and privacy support may be required.
- LM-db:2 LMs may reply to LMc query about location information for a prefix of MN (pull).
Parameters:
- IP prefix of MN: integrity support required and privacy support may be required,
 - IP address of FM-DP/DPA/DPN to forward the packets of the flow: integrity support required.
- LM-db:3 LMs may inform LMc about location information for a prefix of MN (push).
Parameters:
- IP prefix of MN: integrity support required and privacy support may be required,
 - IP address of FM-DP/DPA/DPN to forward the packets of the flow: integrity support required.

This function in the PMIPv6 protocol is the Update Notification (UPN) together with the Update Notification Acknowledgment (UPA) as defined in [RFC7077].

LM-db:4 LMc may inform LMs about update location information for a prefix of MN.
Parameters:

- IP prefix of MN: integrity support required and privacy support may be required,
- IP address of FM-DP/DPA/DPN to forward the packets of the flow: integrity support required.

This function in the MIPv6 / PMIPv6 protocol is the Binding Update (BU) / Proxy Binding Update (PBU) together with the Binding Acknowledgment (BA) / Proxy Binding Acknowledgment (PBA) as defined in [RFC6275] / [RFC5213] respectively.

LM-db:5 The MN may be a host or a router. When the MN is an MR, the prefix information may include the IP prefix delegated to the MR.
Additional parameters:

- IP prefix delegated to MR: integrity support required and privacy support may be required,
- IP prefix/address of the MR to forward the packets of the prefix delegated to the MR: integrity support required.

LM-svr: The LM may be a distributed database with multiple LMs servers.

For example:

LM-svr:1 A LMs may join a pool of LMs servers.
Parameters:

- IP address of the LMs: integrity support required,
- IP prefixes for which the LMs will host the primary location information: integrity support required.

LM-svr:2 LMs may query a peer LMs about location information for a prefix of MN.
Parameters:

- IP prefix: integrity support required and privacy support may be required.

LM-svr:3 LMs may reply to a peer LMs about location information for a prefix of MN.
Parameters:

- IP prefix of MN: integrity support required and privacy support may be required,
- IP address of FM-DP/DPA/DPN to forward the packets of the flow: integrity support required.

The list above only gives the minimal set of the required parameters. In a specific mobility protocol, additional parameters should be added as needed. Examples of these additional parameters are those passed in the mobility options of the mobility header for MIPv6 [RFC6275] and for PMIPv6 [RFC5213].

3.2.2. Forwarding Management

Forwarding management configurations:

FM-cfg: As shown in Section 3.1:

FM-CP may be implemented at CPA, CPN, MN depending on the configuration chosen.

FM-DP may also be implemented at CPA, CPN, MN depending on the configuration chosen.

Specifically:

- FM-cfg:1 FM-CP and FM-DP may be implemented at CPA and DPA respectively in a flat network with network-based mobility as shown in Figure 1(a) and Figure 1(b) in Section 3.1.1.
- FM-cfg:2 FM-CP may be implemented at both CPA and CPN and FM-DP is implemented at both DPA and DPN in a hierarchical network with network-based mobility as shown in Figure 2(a) and Figure 2(b) in Section 3.1.2.
- FM-cfg:3 FM-CP and FM-DP may be implemented at CPA and DPA respectively and also both implemented at MN for host-based mobility as shown in Figure 3(a) and Figure 3(b) in Section 3.1.3.
- FM-cfg:4 FM-CP and FM-DP may be implemented at CPA and DPA respectively and also both implemented at MR for network mobility as shown in Figure 4(a) and Figure 4(b) in Section 3.1.4.

Forwarding management operations and parameters:

- FM-find:1 An anchor may discover and be discovered such as through an anchor registration system as follows:
- FM-find:2 FM registers and authenticates itself with a centralized mobility controller.
Parameters:
- IP address of DPA and its CPA: integrity support required,
 - IP prefix anchored to the DPA: integrity support required.
- Registration reply: acknowledge of registration and echo the input parameters.
- FM-find:3 FM discovers the FM of another IP prefix by querying the mobility controller based on the IP prefix.
Parameters:
- IP prefix of MN: integrity support required and privacy support may be required.
- FM-find:4 When making anchor discovery FM expects the answer parameters:
- IP address of DPA to which IP prefix of MN is anchored: integrity support required,
 - IP prefix of the corresponding CPA: integrity support required.
- FM-flow:1 The FM may be carried out on the packets to/from an MN up to the granularity of a flow.
- FM-flow:2 Example matching parameters are in the 5-tuple of a flow.
- FM-path:1 FM may change the forwarding path of a flow upon a change of point of attachment of an MN. Prior to the changes, packets coming from the CN to the MN would traverse from the CN to the home network anchor of the flow for the MN before reaching the MN. Changes are from this original forwarding path or paths to a new forwarding path or paths from the CN to the current AR of the MN and then the MN itself.
- FM-path:2 As an incoming packet is forwarded from the CN to the MN, the far end where forwarding path change begins may in

general be any node in the original forwarding path from the CN to the home network DPA. The packet is forwarded to the MN for host-based mobility and to a node in the network which will deliver the packets to the MN for network-based mobility. The near-end is generally a DPN with a hierarchical network but may also be another node with DPA capability in a flattened network.

FM-path:3 The mechanisms to accomplish such changes may include changes to the forwarding table and indirection such as tunneling, rewriting packet header, or NAT.

Note: An emphasis in this document in distributed mobility anchoring is to explain the use of multiple anchors to avoid unnecessarily long route which may be encountered in centralized mobility anchoring. It is therefore not the emphasis of this document on which particular mechanism to choose from.

FM-path-tbl:4 The objective of forwarding table updates is to change the forwarding path so that the packets in the flow will be forwarded from the CN to the new AR instead of the home network anchor or previous AR. Each of the affected forwarding switches will need appropriate changes to its forwarding table.

Specifically, such forwarding table updates may include: (1) addition of forwarding table entries needed to forward the packets destined to the MN to the new AR; (2) deletion of forwarding table entries to forward the packets destined to the MN to the home network anchor or to the previous AR.

FM-path-tbl:5 Forwarding table updates may be triggered using DHCPv6-PD prefix delegation to change the role of IP anchoring from the home network anchor or previous AR (with FM-DP) to the new anchor (with FM-DP) to which the MN is currently attached. The new anchor will then advertise routes for the delegated prefix.

With a distributed routing protocol, the updates spread out from neighbors to neighbors and will affect all the forwarding switches such that the packets sent from "any" node to MN will go to the new AR.

FM-path-tbl:6 Forwarding table updates may also be achieved through BGP update as described in [I-D.templin-aerolink],

[I-D.mccann-dmm-flatarch] and also for 3GPP Evolved Packet Core (EPC) network in [I-D.matsushima-stateless-uplane-vepc] when the scope and response time can be managed.

- FM-path-tbl:7 Alternatively, with a centralized control plane, forwarding table updates may be achieved through messaging between the centralized control plane and the distributed forwarding switches as described above (FM-cpdp) in this section.
- FM-path-tbl:8 To reduce excessive signaling, the scope of such updates for a given flow may be confined to only those forwarding switches such that only the packets sent from the "CN" to the MN will go to the new AR. Such confinement may be made when using a centralized control plane possessing a global view of all the forwarding switches.
- FM-path-tbl:9 FM reverts the changes previously made to the forwarding path of a flow when such changes are no longer needed, e.g., when all the ongoing flows using an IP prefix/address requiring IP session continuity have closed. When using DHCPv6-PD, the forwarding paths will be reverted upon prefix lease expiration.
- FM-path-ind:10 Indirection forwards the incoming packets of the flow from the DPA at the far end to a DPA/DPN at the near end of indirection. Both ends of the indirection need to know the LM information of the MN for the flow and also need to possess FM capability to perform indirection.
- FM-path-ind:11 The mechanism of changing the forwarding path in MIPv6 [RFC6275] and PMIPv6 [RFC5213] is tunneling. In the control plane, the FM-CP sets up the tunnel by instructing the FM-DP at both ends of the tunnel. In the data plane, the FM-DP at the start of the tunnel performs packet encapsulation, whereas the FM-DP at the end of the tunnel decapsulates the packet.
- Note that in principle the ends of the indirection path can be any pair of network elements with the FM-DP function.
- FM-path-ind:12 FM reverts the changes previously made to the forwarding path of a flow when such changes are no

longer needed, e.g., when all the ongoing flows using an IP prefix/address requiring IP session continuity have closed. When tunneling is used, the tunnels will be torn down when they are no longer needed.

FM-cpdp: With separation of control plane function and data plane function, FM-CP and FM-DP communicate with each other. Such communication may be realized by the appropriate messages in [I-D.ietf-dmm-fpc-cpdp].

For example:

FM-cpdp:1 CPA/FM-CP sends forwarding table updates to DPA/FM-DP.
Parameters:

- New forwarding table entries to add: integrity support required,
- Expired forwarding table entries to delete: integrity support required.

FM-cpdp:2 DPA/FM-DP sends to CPA/FM-CP about its status and load.
Parameters:

- State of forwarding function being active or not: integrity support required,
- Loading percentage: integrity support required.

FM-CPA: The CPA possesses FM-CP function to make the changes to the forwarding path as described in FM-path, and the changes may be implemented through forwarding table changes or through indirection as described respectively in FM-path-tbl and FM-path-ind above.

The FM-CP communicates with the FM-DP using the appropriate messages in [I-D.ietf-dmm-fpc-cpdp] as described in FM-cpdp above so that it may instruct the FM-DP to perform the changed forwarding tasks.

FM-DPA: The DPA possesses FM-DP function to forward packets according to the changed forwarding path as described in FM-path, and also FM-path-tbl or FM-path-ind depending on whether forwarding table changes or indirection is used.

The FM-DP communicates with the FM-CP using the appropriate messages in [I-D.ietf-dmm-fpc-cpdp] as described in FM-cpdp above so that it may perform the changed forwarding tasks.

The operations and their parameters for the DPA to perform distributed mobility management are described below:

- FM-DPA:1 The DPAs perform the needed functions such that for the incoming packets from the CN, forwarding path change by FM is from the DPA at the far end which may be at any forwarding switch (or even CN itself) in the original forwarding path to the near end DPA/DPN.
- FM-DPA:2 It is necessary that any incoming packet from the CN of the flow must traverse the DPA (or at least one of the DPAs, e.g., in the case of anycast) at the far end in order for the packet to detour to a new forwarding path. Therefore a convenient design is to locate the far end DPA at a unique location which is always in the forwarding path. This is the case in a centralized mobility design where the DPA at the far end is the home network anchor of the flow.
- Distributed mobility however may place the far end DPA at other locations in order to avoid unnecessarily long route.
- FM-DPA:3 With multiple nodes possessing DPA capabilities, the role of FM to begin path change for the incoming packets of a flow at the home network DPA at the far end may be passed to or added to that of another DPA.
- In particular, this DPA role may be moved upstream from the home network DPA in the original forwarding path from CN to MN.
- FM-DPA:4 Optimization of the new forwarding path may be achieved when the path change for the incoming packets begins at a DPA where the original path and the direct IPv6 path overlap. Then the new forwarding path will resemble the direct IPv6 path from the CN to the MN.
- FM-DPA-tbl:5 One method to support IP mobility is through forwarding table changes triggered using DHCPv6-PD to change the role of IP anchoring from the home network anchor (DPA with FM-DP) to the new anchor (DPA with FM-DP). It therefore puts the near end of the path change at the new DPA. Forwarding table updates will subsequently propagate upstream from this DPA up to a far end DPA

where the original path and the direct IPv6 path overlap.

When that far end is too far upstream the signaling of forwarding table updates may become excessive. An alternative is to use indirection (see FM-DPA-ind) from that far end to the new DPA at the near end.

Still another alternative is to combine forwarding table update with indirection.

- FM-DPA-tbl:6 Changes made by FM to the forwarding tables, which are IPv6 nodes, at the ends of the path change for a flow will be reverted when the mobility support for the flow is no longer needed, e.g., when the flows have terminated.
- FM-DPA-ind:7 An alternative mobility support is indirection from the far end DPA to the near end DPA. Both DPAs need to be capable to performing indirection. For incoming packets from the CN to the MN, the far end DPA needs to start the indirection towards the near end DPA, which will be the receiving end of indirection. In addition, the near end DPA needs to continue the forwarding of the packet towards the MN, such as through L2 forwarding or through another indirection towards the MN.
- FM-DPA-ind:8 With indirection, locating or moving the FM function to begin indirection upstream along the forwarding path from CN to MN again may help to reduce unnecessarily long paths.
- FM-DPA-ind:9 Changes made by FM to establish indirection at the DPA and DPN, which are IPv6 nodes, at the ends of the path change for a flow will be reverted when the mobility support for the flow is no longer needed, e.g., when the flows have terminated.
- FM-state:1 In addition to the above, a flow/session may contain states with the required information for QoS, charging, etc. as needed. These states need to be transferred from the old anchor to the new anchor.

FM-buffer: An anchor can buffer packets of a flow in a mobility event:

FM-buffer:1 CPA/FM-CP informs DPA/FM-DP to buffer packets of a flow.
Trigger:

- MN leaves DPA in a mobility event.

Parameters:

- IP prefix of the flow for which packets need to be buffered: integrity support required

FM-buffer:2 CPA/FM-CP on behalf of a new DPA/FM-DP informs the CPA/FM-CP of the prior DPA/FM-DP that it is ready to receive any buffered packets of a flow.

Parameters:

- Destination IP prefix of the flow's packets: integrity support required,
- IP address of the new DPA: integrity support required.

FM-mr:1 When the MN is a mobile router (MR) the access router anchoring the IP prefix of the MR will also own the IP prefix or prefixes to be delegated to the MR. The MNNs in the network carried by the MR obtain IP prefixes from the MR.

FM-mr:2 When the MR moves from a previous AR to a new AR, the MNNs move with the MR. Network mobility support for these MNNs may be provided by forwarding table updates such that packets destined to the MNNs will be forwarded towards the new AR instead of towards the old AR.

Changes to forwarding table entries may occur at the new AR and the aggregate router as well as other affected switches/routers between them such that packets destined to the MNNs will be forwarded to the new AR.

Meanwhile, changes to forwarding table entries may also occur at the old AR and the aggregate router as well as other affected switches/routers between them such that packets destined to the MNNs will not be forwarded to the old AR.

4. IP Mobility Handling in Distributed Anchoring Environments - Mobility Support Only When Needed

IP mobility support may be provided only when needed instead of being provided by default. The LM and FM functions in the different configurations shown in Section 3.1 are then utilized only when needed.

A straightforward choice of mobility anchoring is for a flow to use the IP prefix of the network to which the MN is attached when the flow is initiated [I-D.seite-dmm-dma].

The IP prefix/address at the MN's side of a flow may be anchored at the access router to which the MN is attached. For example, when an MN attaches to a network (Net1) or moves to a new network (Net2), an IP prefix from the attached network is assigned to the MN's interface. In addition to configuring new link-local addresses, the MN configures from this prefix an IP address which is typically a dynamic IP address. It then uses this IP address when a flow is initiated. Packets to the MN in this flow are simply forwarded according to the forwarding table.

There may be multiple IP prefixes/addresses that an MN can select when initiating a flow. They may be from the same access network or different access networks. The network may advertise these prefixes with cost options [I-D.mccann-dmm-prefixcost] so that the mobile node may choose the one with the least cost. In addition, these IP prefixes/addresses may be of different types regarding whether mobility support is needed [I-D.ietf-dmm-ondemand-mobility]. A flow will need to choose the appropriate one according to whether it needs IP mobility support.

4.1. No Need of IP Mobility: Changing to New IP Prefix/Address

When IP mobility support is not needed for a flow, the LM and FM functions are not utilized so that the configurations in Section 3.1 are simplified as shown in Figure 5.

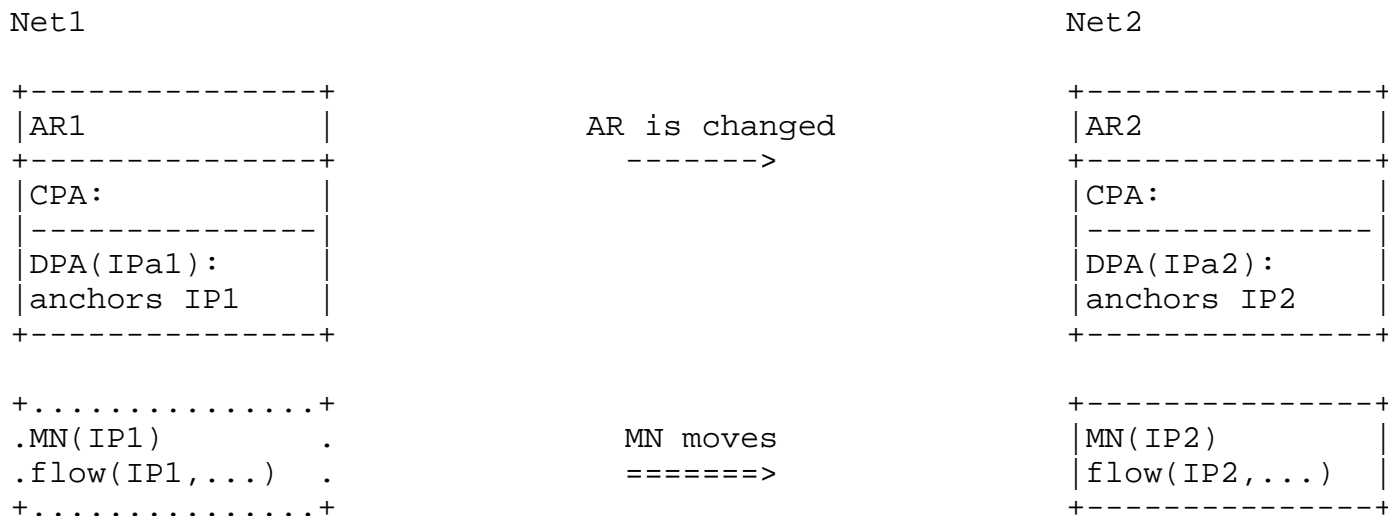

Figure 5. Changing to the new IP prefix/address. MN running a flow using IP1 in a network Net1 changes to running a flow using IP2 in Net2.

When there is no need to provide IP mobility to a flow, the flow may use a new IP address acquired from a new network as the MN moves to the new network.

Regardless of whether IP mobility is needed, if the flow has terminated before the MN moves to a new network, the flow may subsequently restart using the new IP address assigned from the new network.

When IP session continuity is needed, even if a flow is ongoing as the MN moves, it may still be desirable for the flow to change to using the new IP prefix configured in the new network. The flow may then close and then restart using a new IP address configured in the new network. Such a change in the IP address of the flow may be enabled using a higher layer mobility support which is not in the scope of this document.

In Figure 5, a flow initiated while the MN was using the IP prefix IP1 anchored to a previous access router AR1 in network Net1 has terminated before the MN moves to a new network Net2. After moving to Net2, the MN uses the new IP prefix IP2 anchored to a new access router AR2 in network Net2 to start a new flow. The packets may then be forwarded without requiring IP layer mobility support.

An example call flow is outlined in Figure 6.

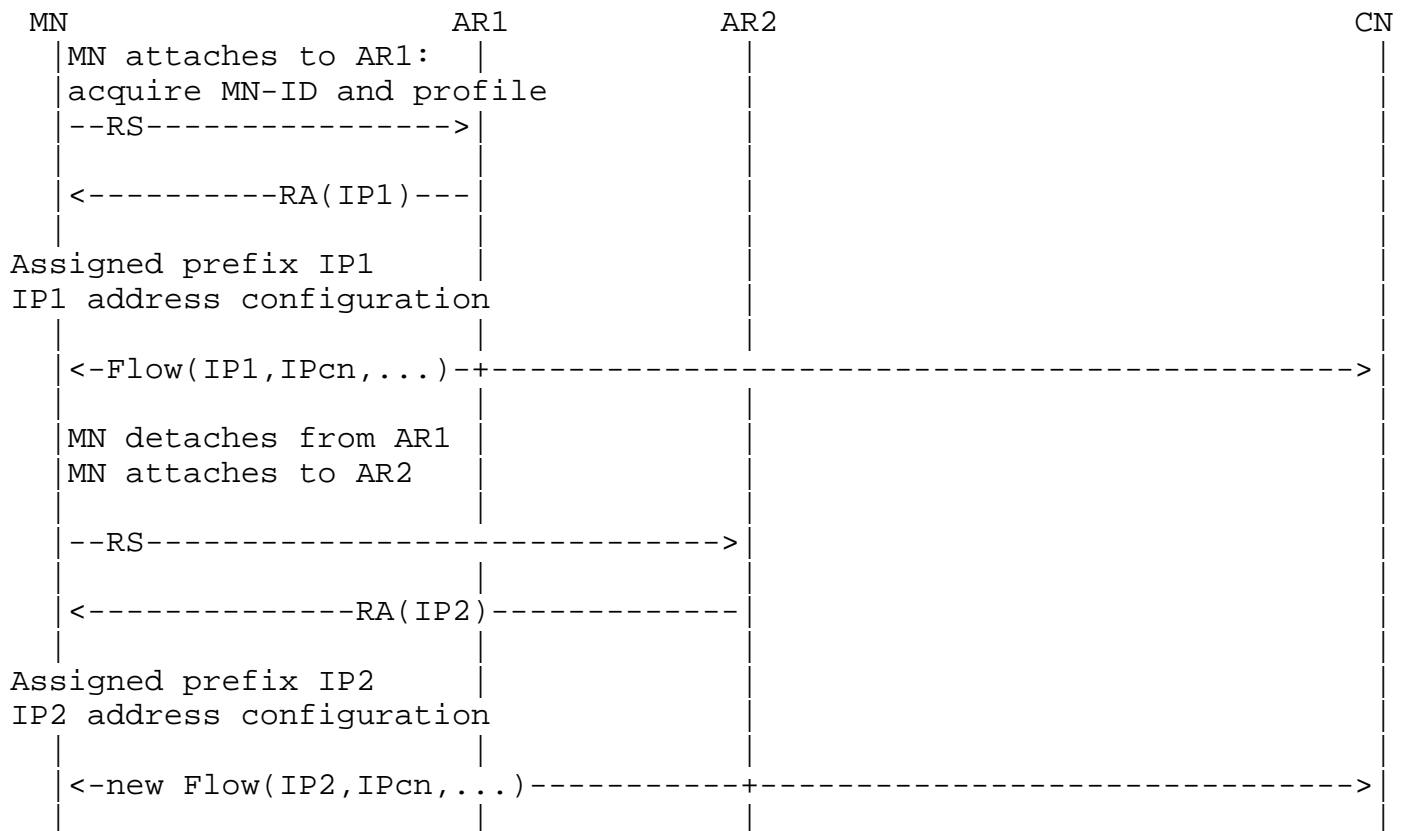

Figure 6. Re-starting a flow to use the IP prefix assigned from the network at which the MN is attached.

4.1.1.1. Guidelines for IPv6 Nodes: Changing to New IP Prefix/Address

A network or network slice may not need IP mobility support. For example, a network slice for stationary sensors only will never encounter mobility.

The standard functions in IPv6 already include dropping the old IPv6 prefix/address and acquiring new IPv6 prefix/address when the node changes its point of attachment to a new network. Therefore, a network or network slice not providing IP mobility support at all will not need any of the functions with the mobility operations and messages described in Section 3.2.

On the other hand, a network or network slice supporting a mix of flows both requiring and not requiring IP mobility support will need the mobility functions, which it will invoke or not invoke as needed.

The guidelines for the IPv6 nodes in a network or network slice supporting a mix of flows both requiring and not requiring IP mobility support include the following:

- GL-cfg:1 A network or network slice supporting a mix of flows both requiring and not requiring mobility support may take any of the configurations described in Section 3.1 and need to implement at the appropriate IPv6 nodes the mobility functions LM and FM as described respectively in LM-cfg and FM-cfg in Section 3.2 according to the configuration chosen.
- GL-mix:1 These mobility functions perform some of the operations with the appropriate messages as described in Section 3.2 depending on which mobility mechanisms are being used. Yet these mobility functions must not be invoked for a flow that does not need IP mobility support so that it is necessary to be able to distinguish the needs of a flow. The guidelines for the MN and the AR are in the following.
- GL-mix:2 Regardless of whether there are flows requiring IP mobility support, when the MN changes its point of attachment to a new network, it needs to configure a new global IP address for use in the new network in addition to configuring the new link-local addresses.
- GL-mix:3 The MN needs to check whether a flow needs IP mobility support. This can be performed when the application is initiated. The specific method is not in the scope of this document.
- GL-mix:4 The information of whether a flow needs IP mobility support is conveyed to the network such as by choosing an IP address to be provided with mobility support as described in [I-D.ietf-dmm-ondemand-mobility]. Then as the MN attaches to a new network, if the MN was using an IP address that is not supposed to be provided with mobility support, the access router will not invoke the mobility functions described in Section 3.2 for this IP address. That is, the IP address from the prior network is simply not used in the new network.

The above guidelines are only to enable distinguishing whether there is need of IP mobility support for a flow that does not. When the flow needs IP mobility support, the list of guidelines will continue in Section 4.2.1.

4.2. Need of IP Mobility

When IP mobility is needed for a flow, the LM and FM functions in Section 3.1 are utilized. The mobility support may be provided by IP prefix anchor switching to the new network to be described in Section 5 or by using other mobility management methods ([Paper-Distributed.Mobility], [Paper-Distributed.Mobility.PMIP] and [Paper-Distributed.Mobility.Review]). Then the flow may continue to use the IP prefix from the prior network of attachment. Yet some time later, the user application for the flow may be closed. If the application is started again, the new flow may not need to use the prior network's IP address to avoid having to invoke IP mobility support. This may be the case where a dynamic IP prefix/address rather than a permanent one is used. The flow may then use the new IP prefix in the network where the flow is being initiated. Routing is again kept simpler without employing IP mobility and will remain so as long as the MN which is now in the new network has not moved again and left to another new network.

An example call flow in this case is outlined in Figure 7.

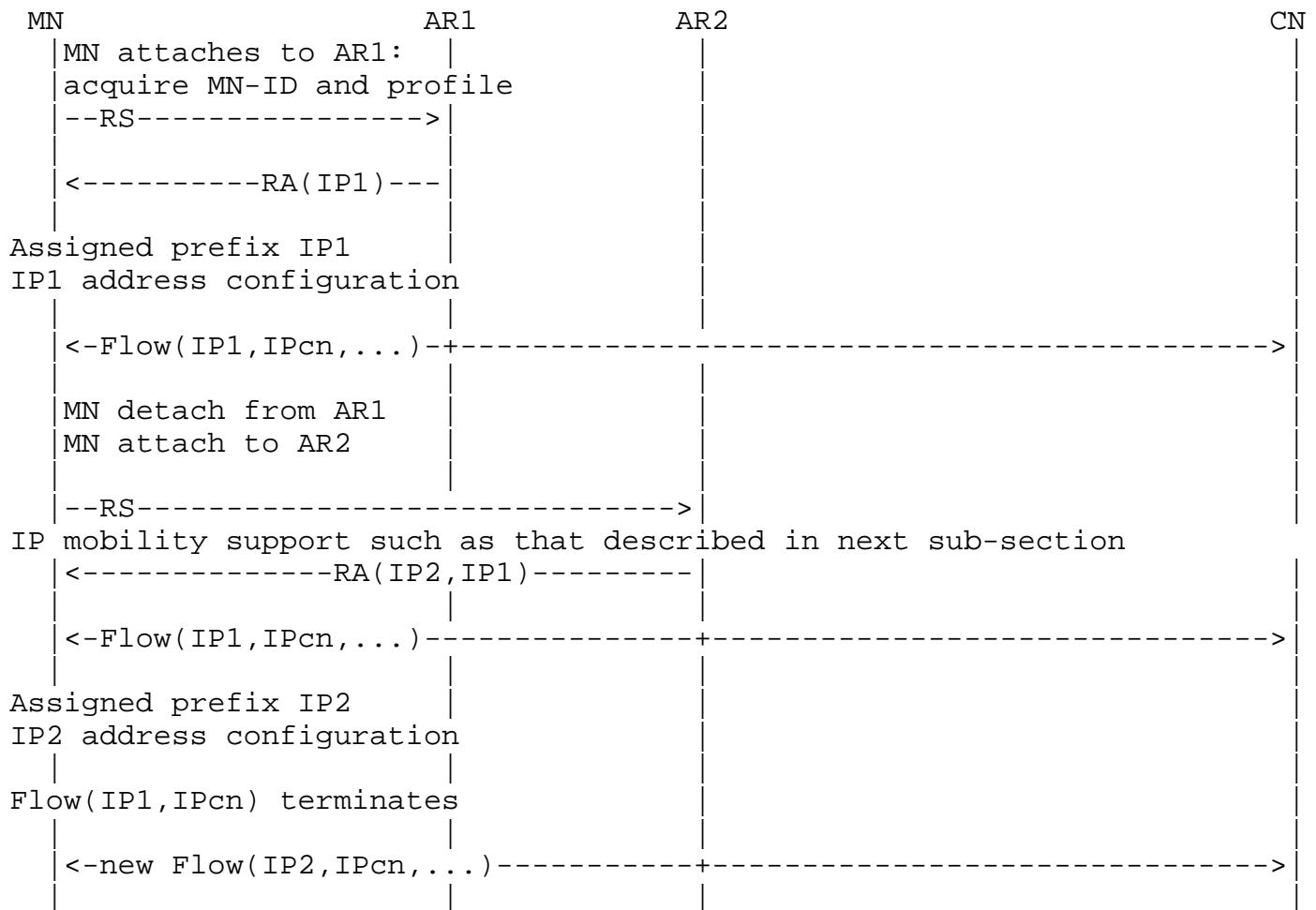

Figure 7. A flow continues to use the IP prefix from its home network after MN has moved to a new network.

4.2.1. Guidelines for IPv6 Nodes: Need of IP Mobility

The configuration guidelines of distributed mobility for the IPv6 nodes in a network or network slice supporting a mix of flows both requiring and not requiring distributed mobility support are as follows:

- GL-cfg:2 Multiple instances of DPAs (at access routers) which are providing IP prefix to the MNs are needed to provide distributed mobility anchoring in an appropriate configuration such as those described in Figure 1 (Section 3.1.1) for network-based distributed mobility or in Figure 3 (Section 3.1.3) for host-based distributed mobility.

The appropriate IPv6 nodes (CPA, DPA, CPN, DPN) have to implement the mobility functions LM and FM as described respectively in LM-cfg and FM-cfg in Section 3.2 according to the configuration chosen.

The guidelines of distributed mobility for the IPv6 nodes in a network or network slice supporting a mix of flows both requiring and not requiring distributed mobility support had begun with those given as GL-mix in Section 4.1.1 and continue as follows:

- GL-mix:5 The distributed anchors may need to message with each other. When such messaging is needed, the anchors may need to discover each other as described in the FM operations and mobility message parameters (FM-find) in Section 3.2.2.
- GL-mix:6 The anchors may need to provide mobility support on a per-flow basis as described in the FM operations and mobility message parameters (FM-flow) in Section 3.2.2.
- GL-mix:7 Then the anchors need to properly forward the packets of the flows in the appropriate FM operations and mobility message parameters depending on the specific mobility mechanism as described in Section 3.2.2.
- GL-mix:8 When using a mechanism of changing forwarding table entries, the FM operations and mobility message parameters are described in FM-path, FM-path-tbl, FM-DPA, and FM-DPA-tbl in Section 3.2.2.

The forwarding table updates will take place at AR1, AR2, the far end DPA, and other affected switches/routers such that the packet from the CN to the MN will traverse from the far end DPA towards AR2 instead of towards AR1.

Therefore new entries to the forwarding table will be added at AR2 and the far end DPA as well as other affected switches/routers between them so that these packets will traverse towards AR2. Meanwhile, changes to the forwarding table entries will also occur at AR1 and the far end DPA as well as other affected switches/routers between them so that if these packets ever reaches any of them, they will not traverse towards AR1 but will traverse towards AR2 (see Section 3.2.2).

- GL-mix:9 Alternatively when using a mechanism of indirection, the FM operations and mobility message parameters are described in FM-path, FM-path-ind, FM-DPA, and FM-DPA-ind in Section 3.2.2.

GL-mix:10 If there are in-flight packets toward the old anchor while the MN is moving to the new anchor, it may be necessary to buffer these packets and then forward to the new anchor after the old anchor knows that the new anchor is ready. Such procedures are described in the FM operations and mobility message parameters (FM-buffer) in Section 3.2.2.

5. IP Mobility Handling in Distributed Mobility Anchoring Environments - Anchor Switching to the New Network

IP mobility is invoked to enable IP session continuity for an ongoing flow as the MN moves to a new network. Here the anchoring of the IP address of the flow is in the home network of the flow, which is not in the current network of attachment. A centralized mobility management mechanism may employ indirection from the anchor in the home network to the current network of attachment. Yet it may be difficult to avoid unnecessarily long route when the route between the MN and the CN via the anchor in the home network is significantly longer than the direct route between them. An alternative is to switch the IP prefix/address anchoring to the new network.

5.1. IP Prefix/Address Anchor Switching for Flat Network

The IP prefix/address anchoring may move without changing the IP prefix/address of the flow. Here the LM and FM functions in Figures 1(a) and 1(b) in Section 3.1 are implemented as shown in Figure 8.



Figure 8. IP prefix/address anchor switching to the new network. MN with flow using IP1 in Net1 continues to run the flow using IP1 as it moves to Net2.

As an MN with an ongoing session moves to a new network, the flow may preserve IP session continuity by moving the anchoring of the original IP prefix/address of the flow to the new network. BGP UPDATE messages may be used to change the forwarding table entries as described in [I-D.templin-aerolink] and [I-D.mccann-dmm-flatarch] if the response time of such updates does not exceed the handover delay requirement of the flow. An alternative is to use a centralized routing protocol to be described in Section 5.2 with a centralized control plane.

5.1.1. Guidelines for IPv6 Nodes: Switching Anchor for Flat Network

The configuration guideline for a flat network or network slice supporting a mix of flows both requiring and not requiring IP mobility support is:

GL-cfg:3 Multiple instances of DPAs (at access routers) which are providing IP prefix to the MNs are needed to provide distributed mobility anchoring according to Figure 1(a) or Figure 1(b) in Section 3.1 for a flat network.

The appropriate IPv6 nodes (CPA, DPA) have to implement the mobility functions LM and FM as described respectively in LM-cfg:1 or LM-cfg:2 and FM-cfg:1 in Section 3.2.

The guidelines (GL-mix) in Section 4.1.1 and in Section 4.2.1 for the IPv6 nodes for a network or network slice supporting a mix of flows both requiring and not requiring IP mobility support apply here. In addition, the following are required.

- GL-switch:1 The location management provides information about which IP prefix from an AR in the original network is being used by a flow in which AR in a new network. Such information needs to be deleted or updated when such flows have closed so that the IP prefix is no longer used in a different network. The LM operations are described in Section 3.2.1.
- GL-switch:2 The FM functions are implemented through the DHCPv6-PD protocol. Here the anchor operations to properly forward the packets for a flow as described in the FM operations and mobility message parameters in FM-path, FM-path-tbl, FM-DPA, and FM-DPA-tbl in Section 3.2.2 are realized by changing the anchor with DHCPv6-PD and also by reverting such changes later after the application has already closed and when the DHCPv6-PD timer expires. If there are in-flight packets toward the old anchor while the MN is moving to the new anchor, it may be necessary to buffer these packets and then forward to the new anchor after the old anchor knows that the new anchor is ready as are described in FM-buffer in Section 3.2.2. The anchors may also need to discover each other as described also in the FM operations and mobility message parameters (FM-find).
- GL-switch:3 The security management function in the anchor node at a new network must allow to assign the original IP prefix/address used by the mobile node at the previous (original) network. As the assigned original IP prefix/address is to be used in the new network, the security management function in the anchor node must allow to advertise the prefix of the original IP address and also allow the mobile node to send and receive data packets with the original IP address.
- GL-switch:4 The security management function in the mobile node must allow to configure the original IP prefix/address used at the previous (original) network when the original IP prefix/address is assigned by the anchor node in the new network. The security management function in the mobile node also allows to use the original IP address for the previous flow in the new network.

5.2. IP Prefix/Address Anchor Switching for Flat Network with Centralized Control Plane

An example of IP prefix anchor switching is in the case where Net1 and Net2 both belong to the same operator network with separation of control and data planes ([I-D.liu-dmm-deployment-scenario] and [I-D.matsushima-stateless-uplane-vepc]), where the controller may send to the switches/routers the updated information of the forwarding tables with the IP address anchoring of the original IP prefix/address at AR1 moved to AR2 in the new network. That is, the IP address anchoring in the original network which was advertising the prefix will need to move to the new network. As the anchoring in the new network advertises the prefix of the original IP address in the new network, the forwarding tables will be updated so that packets of the flow will be forwarded according to the updated forwarding tables.

The configurations in Figures 1(a) and 1(b) in Section 3.1 for which the FM-CP and the LM are centralized and the FM-DPs are distributed apply here. Figure 9 shows its implementation where the LM is a binding between the original IP prefix/address of the flow and the IP address of the new DPA, whereas the FM uses the DHCPv6-PD protocol.

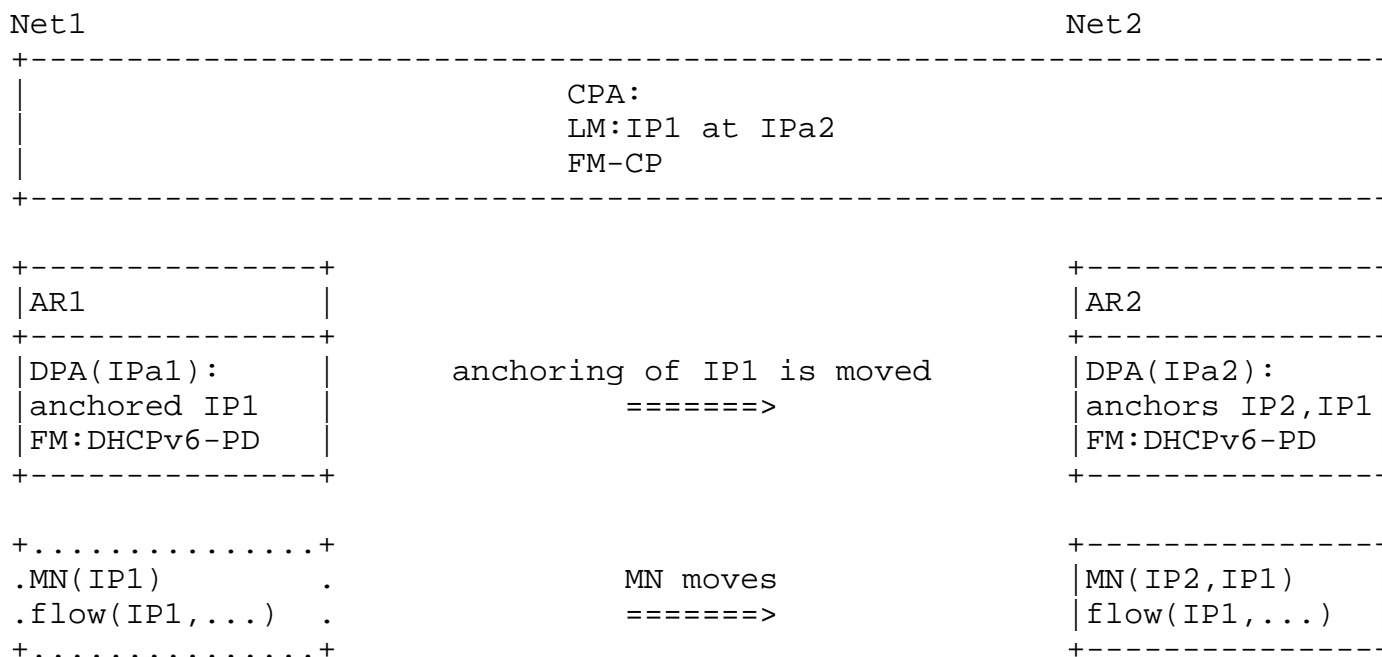

Figure 9. IP prefix/address anchor switching to the new network with the LM and the FM-CP in a centralized control plane whereas the FM-DPs are distributed.

The example call flow in Figure 10 shows that IP1 is assigned to MN when the MN attaches to the AR1. A flow running in MN and needing IP mobility may continue to use the previous IP prefix by moving the anchoring of the IP prefix to the new network. Yet a new flow to be initiated in the new network may simply use a new IP prefix assigned from the new network.

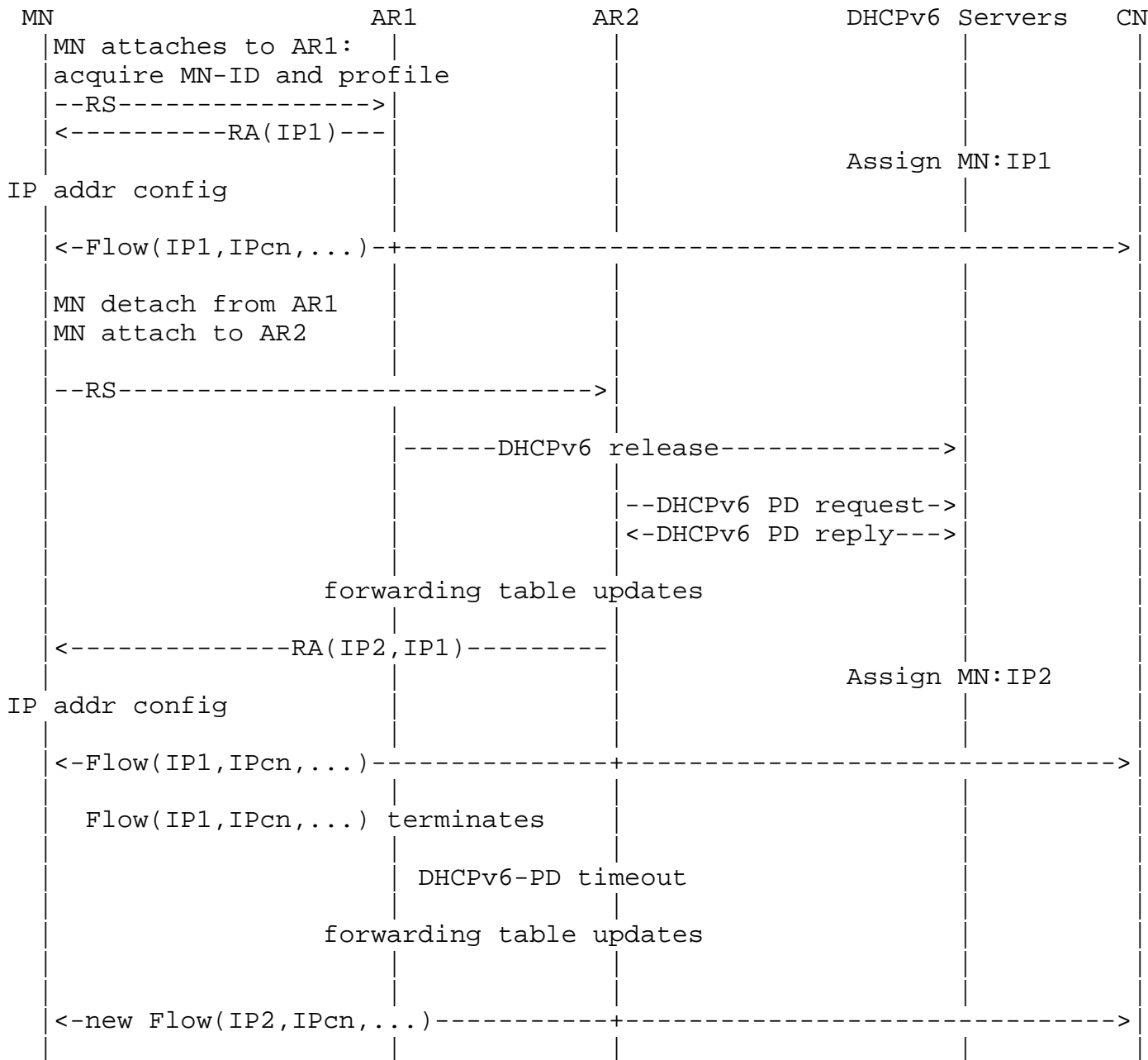

Figure 10. DMM solution. MN with flow using IP1 in Net1 continues to run the flow using IP1 as it moves to Net2.

As the MN moves from AR1 to AR2, the AR1 as a DHCPv6 client may send a DHCPv6 release message to release the IP1. It is now necessary for AR2 to learn the IP prefix of the MN from the previous network so that it will be possible for Net2 to assign both the previous network prefix and the new network prefix. The network may learn the previous prefix in different methods. For example, the MN may provide its previous network prefix information by including it to the RS message [I-D.jhlee-dmm-dnpp].

Knowing that MN is using IP1, the AR2 sends to a DHCPv6 server a DHCPv6-PD request to move the IP1 to AR2. The server sends to AR2 a DHCPv6-PD reply to move the IP1. Then forwarding tables updates will take place here.

In addition, the MN also needs a new IP in the new network. The AR2 may now send RA to the MN with prefix information that includes IP1 and IP2. The MN may then continue to use IP1. In addition, the prefix IP2 is assigned to the MN which may configure the IP addresses of its interface. Now for flows using IP1, packets destined to IP1 will be forwarded to the MN via AR2.

As such flows have terminated and DHCPv6-PD has timed out, IP1 goes back to Net1. MN will then be left with IP2 only, which it will use when it now starts a new flow.

5.2.1. Additional Guidelines for IPv6 Nodes: Switching Anchor with Centralized CP

The configuration guideline for a flat network or network slice with centralized control plane and supporting a mix of flows both requiring and not requiring IP mobility support is:

GL-cfg:4 Multiple instances of DPAs (at access routers) which are providing IP prefix to the MNs are needed to provide distributed mobility anchoring according to Figure 1(a) or Figure 1(b) in Section 3.1 with centralized control plane for a flat network.

At the appropriate IPv6 nodes (CPA, DPA) have to implement the mobility functions LM and FM as described respectively in LM-cfg:1 or LM-cfg:2 and FM-cfg:1 in Section 3.2.

The guidelines (GL-mix) in Section 4.1.1 and in Section 4.2.1 for the IPv6 nodes for a network or network slice supporting a mix of flows both requiring and not requiring IP mobility support apply here. The guidelines (GL-mix) in Section 5.1.1 for moving anchoring for a flat network also apply here. In addition, the following are required.

- GL-switch:5 It was already mentioned that the anchor operations to properly forward the packets for a flow as described in the FM operations and mobility message parameters in FM-path, FM-path-tbl, FM-DPA, and FM-DPA-tbl in Section 3.2.2 is realized by changing the anchoring with DHCPv6-PD and undoing such changes later when its timer expires and the application has already closed. Here however, with separation of control and data planes for the anchors and where the LMs and the FM-CP are centralized in the same control plane, messaging between anchors and the discovery of anchors become internal to the control plane.
- GL-switch:6 The centralized FM-CP needs to communicate with the distributed FM-DP using the FM operations and mobility message parameters as described in FM-cpdp in Section 3.2.2. Such may be realized by the appropriate messages in [I-D.ietf-dmm-fpc-cpdp].
- GL-switch:7 It was also already mentioned before that, if there are in-flight packets toward the previous anchor while the MN is moving to the new anchor, it may be necessary to buffer these packets and then forward to the new anchor after the old anchor knows that the new anchor is ready. Here however, the corresponding FM operations and mobility message parameters as described in Section 3.2.2 (FM-buffer) can be realized by the internal operations in the control plane together with signaling between the control plane and distributed data plane. These signaling may be realized by the appropriate messages in [I-D.ietf-dmm-fpc-cpdp].

5.3. Hierarchical Network

The configuration for a hierarchical network has been shown in Figures 2(a) and 2(b) in Section 3.1.2. With centralized control plane, CPA and CPN, with the associated LM and FM-CP are all co-located. There are multiple DPAs (each with FM-DP) in distributed mobility anchoring. In the data plane, there are multiple DPNs (each with FM-DP) hierarchically below each DPA. The DPA at each AR supports forwarding to the DPN at each of a number of forwarding switches (FWs). A mobility event in this configuration belonging to distributed mobility management will be deferred to Section 5.4.

In this distributed mobility configuration, a mobility event involving change of FW only but not of AR as shown in Figure 11 may

still belong to centralized mobility management and may be supported using PMIPv6. This configuration of network-based mobility is also applicable to host-based mobility with the modification for the MN directly taking the role of DPN and CPN, and the corresponding centralized mobility event may be supported using MIPv6.

In Figure 11, the IP prefix assigned to the MN is anchored at the access router (AR) supporting indirection to the old FW to which the MN was originally attached as well as to the new FW to which the MN has moved.

The realization of LM may be the binding between the IP prefix/address of the flow used by the MN and the IP address of the DPN to which MN has moved. The implementation of FM to enable change of FW without changing AR may be accomplished using tunneling between the AR and the FW as described in [I-D.korhonen-dmm-local-prefix] and in [I-D.templin-aerolink] or using some other L2 mobility mechanism.

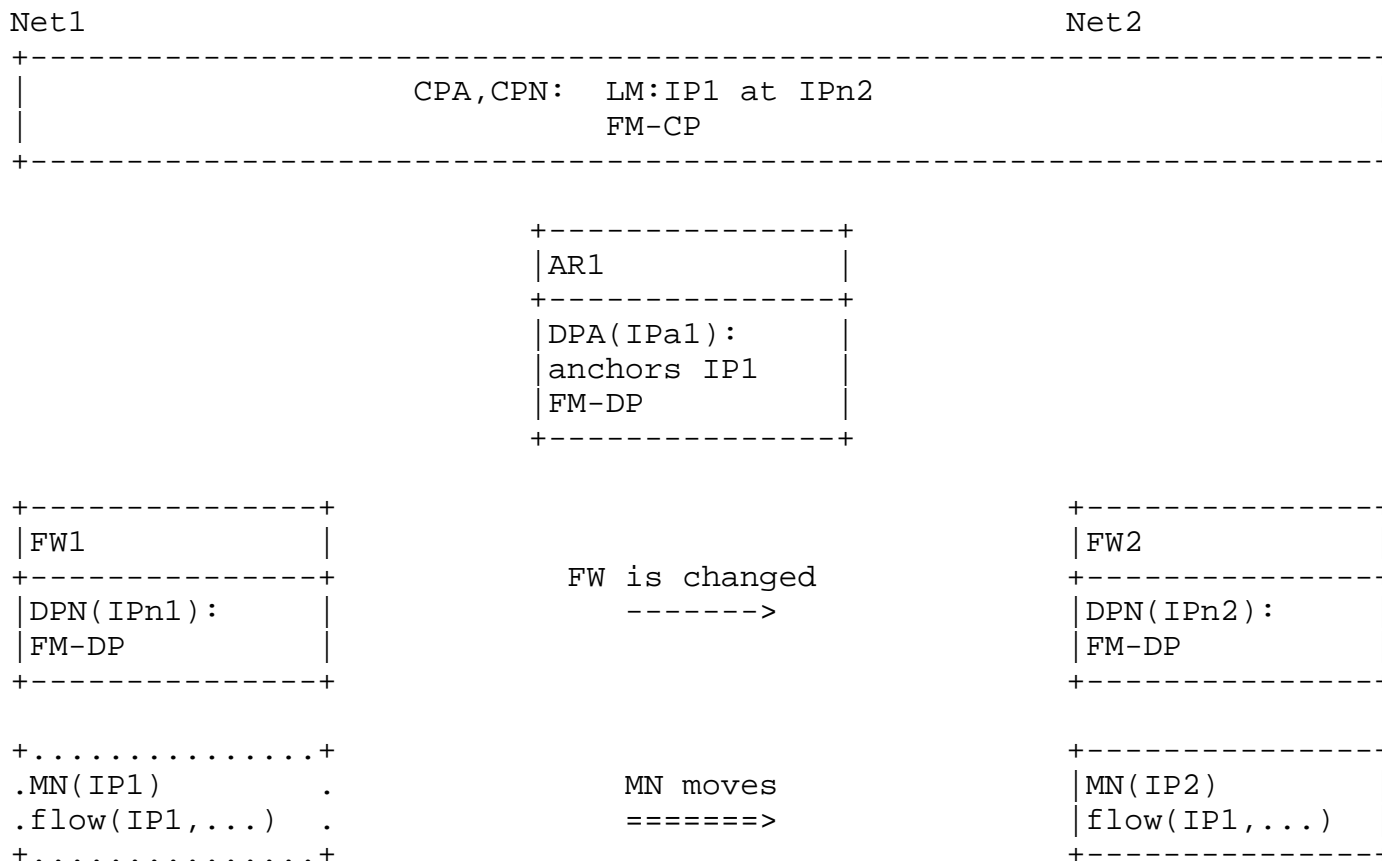

Figure 11. Mobility without involving change of IP anchoring in a network in which the IP prefix assigned to the MN is anchored at an AR which is hierarchically above multiple FWs to which the MN may connect.

5.3.1. Additional Guidelines for IPv6 Nodes: Hierarchical Network with No Anchor Relocation

The configuration guideline for a hierarchical network or network slice with centralized control plane and supporting a mix of flows both requiring and not requiring IP mobility support is:

GL-cfg:5 Multiple instances of DPAs (at access routers) which are providing IP prefix to the MNs are needed to provide distributed mobility anchoring according to Figure 2(a) or Figure 2(b) in Section 3.1.2 with centralized control plane for a hierarchical network.

The appropriate IPv6 nodes (CPA, DPA) have to implement the mobility functions LM and FM as described respectively in LM-cfg:3 or LM-cfg:4 and FM-cfg:2 in Section 3.2.

Even when the mobility event does not involve change of anchor, it is still necessary to distinguish whether a flow needs IP mobility support.

The GL-mix guidelines in Section 4.1.1 and in Section 4.2.1 for the IPv6 nodes for a network or network slice supporting a mix of flows both requiring and not requiring IP mobility support apply here. In addition, the following are required.

GL-switch:8 Here, the LM operations and mobility message parameters described in Section 3.2.1 provide information of which IP prefix from its FW needs to be used by a flow using which new FW. The anchor operations to properly forward the packets of a flow described in the FM operations and mobility message parameters (FM-path, FM-path-ind, FM-cpdp in Section 3.2.2) may be realized with PMIPv6 protocol [I-D.korhonen-dmm-local-prefix] or with AERO protocol [I-D.templin-aerolink] to tunnel between the AR and the FW.

5.4. IP Prefix/Address Anchor Switching for a Hierarchical Network

The configuration for the hierarchical network has been shown in Figures 2(a) and 2(b) in Section 3.1.2. Again, with centralized control plane, CPA and CPN, with the associated LM and FM-CP are all co-located. There are multiple DPAs (each with FM-DP) in distributed mobility anchoring. In the data plane, there are multiple DPNs (each with FM-DP) hierarchically below each DPA. The DPA at each AR supports forwarding to the DPN at each of a number of forwarding switches (FWs).

A distributed mobility event in this configuration involves change from a previous DPN which is hierarchically under the previous DPA to a new DPN which is hierarchically under a new DPA. Such an event involving change of both DPA and DPN is shown in Figure 12.

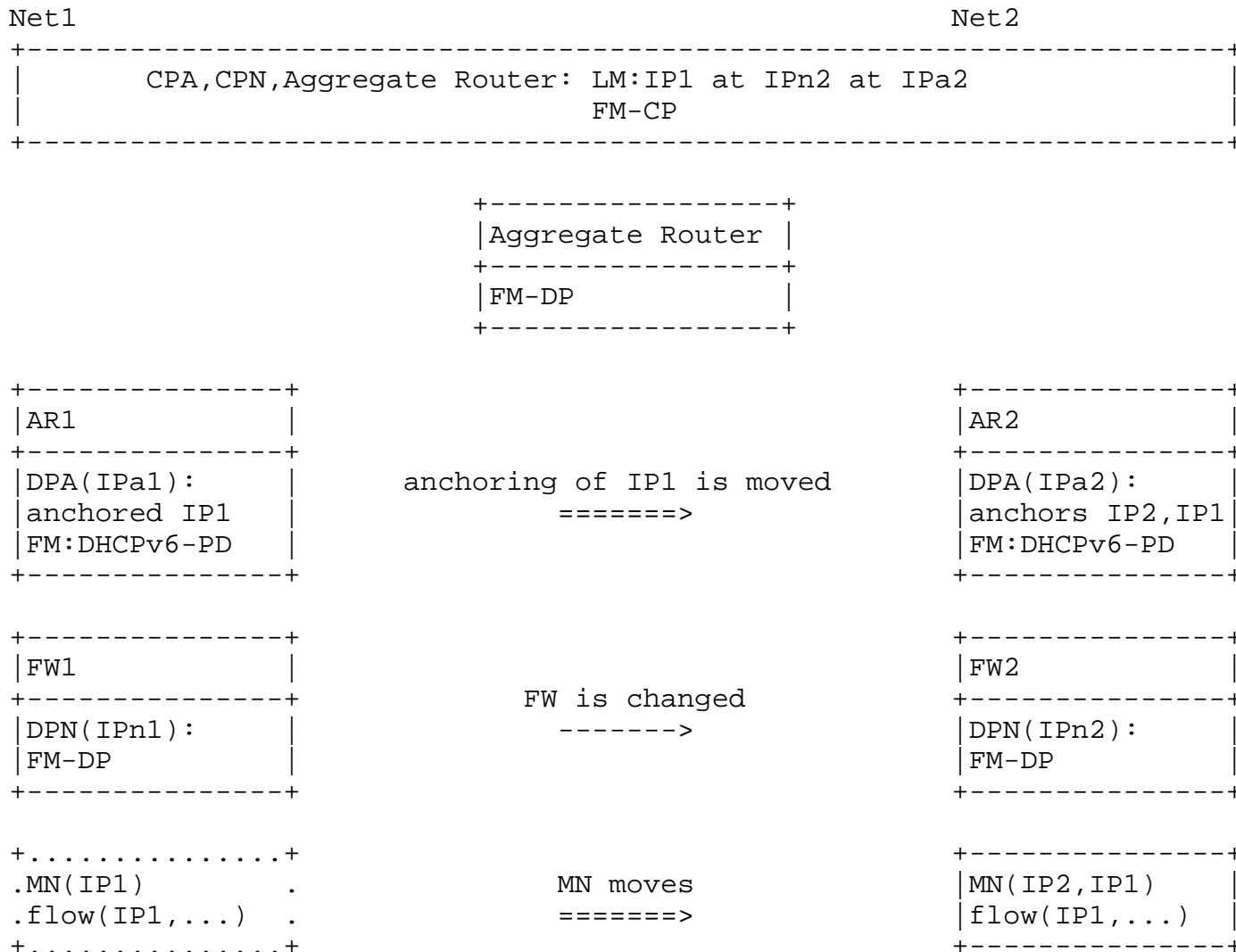

Figure 12. Mobility involving change of IP anchoring in a network with hierarchy in which the IP prefix assigned to the MN is anchored at an Edge Router supporting multiple access routers to which the MN may connect.

This deployment case involves both a change of anchor from AR1 to AR2 and a network hierarchy AR-FW. It can be realized by a combination of relocating the IP prefix/address anchoring from AR1 to AR2 with the mechanism as described in Section 5.2 and then forwarding the packets with network hierarchy AR-FW as described in Section 5.3.

To change the anchoring of IP1, AR1 acting as a DHCPv6-PD client may exchange message with the DHCPv6 server to release the prefix IP1. Meanwhile, AR2 acting as a DHCPv6-PD client may exchange message with the DHCPv6 server to delegate the prefix IP1 to AR2.

5.4.1. Additional Guidelines for IPv6 Nodes: Switching Anchor with Hierarchical Network

The configuration guideline (GL-cfg) for a hierarchical network or network slice with centralized control plane described in Section 5.3.1 applies here.

The GL-mix guidelines in Section 4.1.1 and in Section 4.2.1 for the IPv6 nodes for a network or network slice supporting a mix of flows both requiring and not requiring IP mobility support apply here.

The guidelines (GL-switch) in Section 5.1.1 for anchoring relocation and in Section 5.2.1 for a centralized control plane also apply here.

In addition, the guidelines for indirection between the new DPA and the new DPN as described in Section 5.3.1 apply as well.

5.5. Network Mobility

The configuration for network mobility has been shown in Figures 4(a) and 4(b) in Section 3.1.4. Again, with centralized control plane, CPA, with the associated LM and FM-CP are all co-located. There are multiple DPAs (each with FM-DP) in the data plane in distributed mobility anchoring. The MR possesses the mobility functions FM and LMc. The IP prefix IPn1 is delegated to the MR, to which an MNN is attached and has an IP address from IPn1 assigned to its interface.

Figure 13 shows a distributed mobility event in a hierarchical network with a centralized control plane involving a change of attachment of the MR from a previous DPA to a new DPA while the MNN is attached to the MR and therefore moves with the MR.

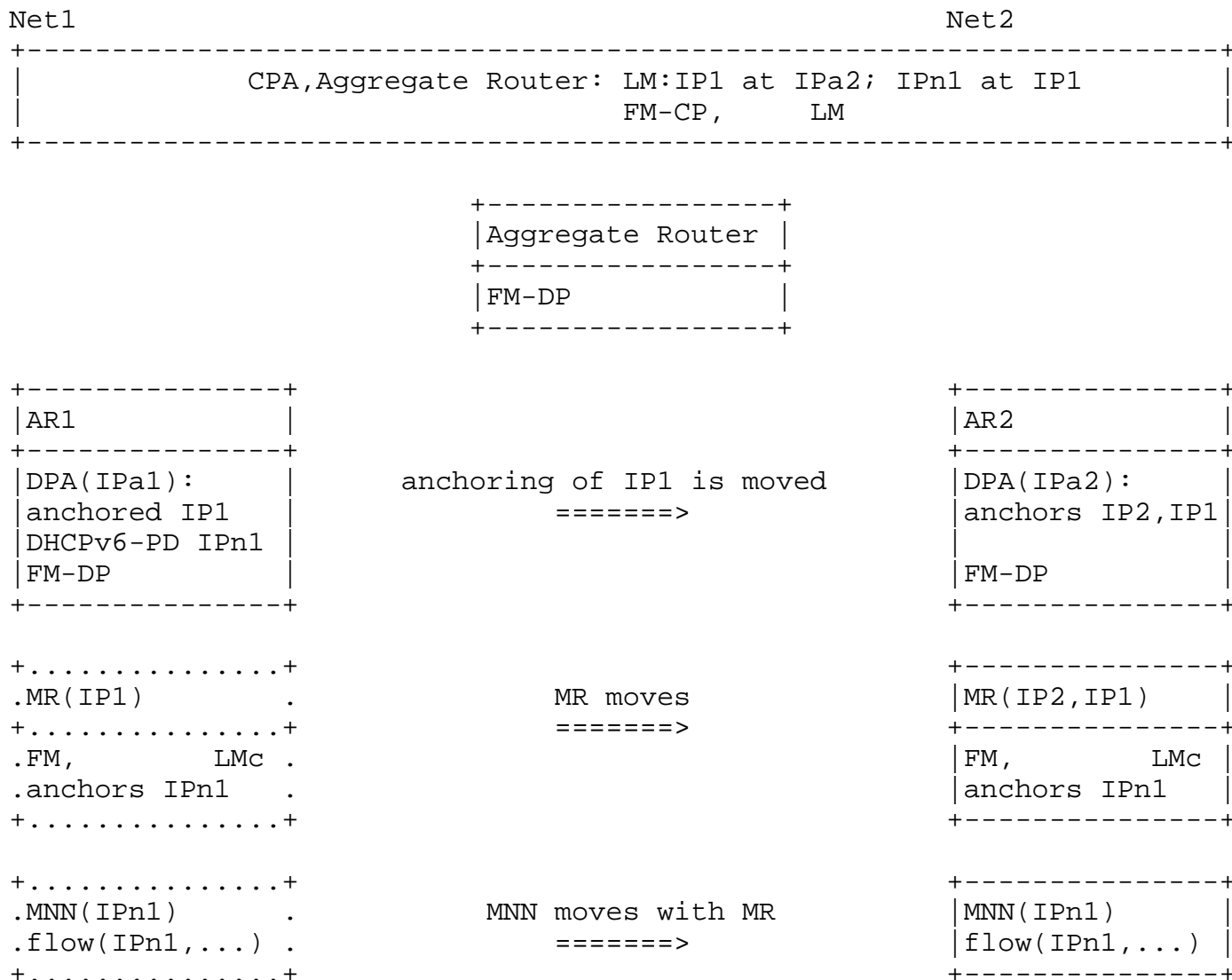

Figure 13. Mobility involving change of IP anchoring for a MR to which an MNN is attached.

As the MR with source IP prefix IP1 moves from AR1 to AR2, mobility support may be provided by moving the anchoring of IP1 from AR1 to AR2 using the mechanism described in Section 5.2.

The forwarding table updates will take place at AR1, AR2, the aggregate router, and other affected routers such that the packet from the CN to the MNN will traverse from the aggregate router towards AR2 instead of towards AR1.

5.5.1. Additional Guidelines for IPv6 Nodes: Network mobility

The configuration guideline for a network or network slice with centralized control plane to provide network mobility is:

GL-cfg:6 Multiple instances of DPAs (at access routers) which are providing IP prefix of the MRs are needed to provide distributed mobility anchoring according to Figure 4(a) or Figure 4(b) in Section 3.1.

The appropriate IPv6 nodes (CPA, DPA) have to implement the mobility functions LM and FM as described respectively in LM-cfg:3 or LM-cfg:4 and FM-cfg:4 in Section 3.2.

The GL-mix guidelines in Section 4.1.1 and in Section 4.2.1 for the IPv6 nodes for a network or network slice supporting a mix of flows both requiring and not requiring IP mobility support apply here.

Here, because the MN is a MR, the following guideline is added:

GL-mix:11 There are no flows requiring network mobility support when there are no MNN attaching to the MR. Here there are also no MNN using a prefix delegated to the MR. Therefore the anchor of the MR may change to a new AR. The new AR may delegate new IP prefix to the AR, so that the MR may support potential MNNs to attach to it. On the other hand the delegation of IP prefix to the MR from the old AR may be deleted.

The guidelines (GL-switch) in Section 5.1.1 for anchoring relocation and in Section 5.2.1 for a centralized control plane also apply here.

Again because the MN is a MR, the following guidelines are added:

GL-switch:9 Network mobility may be provided using the FM operations and mobility message parameters as described in FM-mr in Section 3.2.2.

GL-switch:10 The following changes to forwarding table entries are needed:

New entries to the forwarding tables are added at AR2 and the aggregate router as well as other affected switches/routers between them so that packets from the CN to the MNN destined to IPn1 will traverse towards AR2. Meanwhile, changes to the forwarding table will also occur at AR1 and the aggregate router as well as other affected switches/routers between them so that in

case such packets ever reach any of these switches/routers, the packets will not traverse towards AR1 but will traverse towards AR2.

GL-switch:11 The security management function in the anchor node at a new network must allow the MNN to continue to own the IP prefix/address originally delegated to the MR and used by the MNN at the prior network. As this original IP prefix/address is to be used in the new network, the security management function in the anchor node must allow to advertise the prefix of the original IP address and also allow the MNN to send and receive data packets with the original IP address.

GL-switch:12 The security management function in the mobile router must allow to configure the original IP prefix/address delegated to the MR from the previous (original) network when the original IP prefix/address is being delegated to the MR in the new network. The security management function in the mobile router also allows to use the original IP address by the MNNs for the previous flow in the new network.

6. Security Considerations

Security protocols and mechanisms are employed to secure the network and to make continuous security improvements, and a DMM solution is required to support them [RFC7333]. In a DMM deployment [I-D.ietf-dmm-deployment-models] various attacks such as impersonation, denial of service, man-in-the-middle attacks need to be prevented. An appropriate security management function as defined in Section 2 controls these security protocols and mechanisms to provide access control, integrity, authentication, authorization, confidentiality, etc.

Security considerations are described in terms of integrity support, privacy support etc. in describing the mobility functions in Section 3.2. Here the mobility message parameters used in DMM must be protected, and some parameters require means to support MN and MR privacy. The security considerations are also described in the guidelines for IPv6 nodes in various subsections in Section 4, and Section 5.

The IP address anchoring of an IP prefix is moved from one network to another network to support IP mobility Section 5.1. As is considered in the guidelines for IPv6 nodes in Section 5.1.1, the security management function needs to enable the use in the new network of

attachment the IP prefix assigned from another network. Yet it must do so without compromising on the needed security to prevent the possible misuse of an IP prefix belonging to another network.

In network mobility, the MNN using an IP prefix assigned to it from the MR when the MR was in a prior network moves with the MR to a new network Section 5.5. As is considered in the guidelines for IPv6 nodes in Section 5.5.1 to support IP mobility for an ongoing flow, the security management function needs to enable the continued use of this IP prefix by the MNN with MR in the new network of attachment. Yet it must do so without compromising on the needed security to prevent the possible misuse of an IP prefix belonging to another network.

7. IANA Considerations

This document presents no IANA considerations.

8. Contributors

This document has benefited from other work on mobility solutions using BGP update, on mobility support in SDN network, on providing mobility support only when needed, and on mobility support in enterprise network. These works have been referenced. While some of these authors have taken the work to jointly write this document, others have contributed at least indirectly by writing these drafts. The latter include Philippe Bertin, Dapeng Liu, Satoru Matushima, Peter McCann, Pierrick Seite, Jouni Korhonen, and Sri Gundavelli.

Valuable comments have been received from John Kaippallimalil, ChunShan Xiong, and Dapeng Liu. Dirk von Hugo, Byju Pularikkal, Pierrick Seite have generously provided careful review with helpful corrections and suggestions.

9. References

9.1. Normative References

[I-D.geng-netslices-architecture]

67, 4., Bryant, S., and J. Dong, "Network Slicing Architecture", draft-geng-netslices-architecture-00 (work in progress), March 2017.

[I-D.ietf-dmm-deployment-models]

Gundavelli, S. and S. Jeon, "DMM Deployment Models and Architectural Considerations", draft-ietf-dmm-deployment-models-01 (work in progress), February 2017.

[I-D.ietf-dmm-fpc-cpdp]

Matsushima, S., Bertz, L., Liebsch, M., Gundavelli, S., Moses, D., and C. Perkins, "Protocol for Forwarding Policy Configuration (FPC) in DMM", draft-ietf-dmm-fpc-cpdp-07 (work in progress), March 2017.

[I-D.ietf-dmm-ondemand-mobility]

Yegin, A., Moses, D., Kweon, K., Lee, J., Park, J., and S. Jeon, "On Demand Mobility Management", draft-ietf-dmm-ondemand-mobility-10 (work in progress), January 2017.

[I-D.jhlee-dmm-dnpp]

Lee, J. and Z. Yan, "Deprecated Network Prefix Provision", draft-jhlee-dmm-dnpp-01 (work in progress), April 2016.

[I-D.korhonen-dmm-local-prefix]

Korhonen, J., Savolainen, T., and S. Gundavelli, "Local Prefix Lifetime Management for Proxy Mobile IPv6", draft-korhonen-dmm-local-prefix-01 (work in progress), July 2013.

[I-D.liu-dmm-deployment-scenario]

Liu, V., Liu, D., Chan, A., Lingli, D., and X. Wei, "Distributed mobility management deployment scenario and architecture", draft-liu-dmm-deployment-scenario-05 (work in progress), October 2015.

[I-D.matsushima-stateless-uplane-vepc]

Matsushima, S. and R. Wakikawa, "Stateless user-plane architecture for virtualized EPC (vEPC)", draft-matsushima-stateless-uplane-vepc-06 (work in progress), March 2016.

[I-D.mccann-dmm-flatarch]

McCann, P., "Authentication and Mobility Management in a Flat Architecture", draft-mccann-dmm-flatarch-00 (work in progress), March 2012.

[I-D.mccann-dmm-prefixcost]

McCann, P. and J. Kaippallimalil, "Communicating Prefix Cost to Mobile Nodes", draft-mccann-dmm-prefixcost-03 (work in progress), April 2016.

[I-D.seite-dmm-dma]

Seite, P., Bertin, P., and J. Lee, "Distributed Mobility Anchoring", draft-seite-dmm-dma-07 (work in progress), February 2014.

- [I-D.templin-aerolink] Templin, F., "Asymmetric Extended Route Optimization (AERO)", draft-templin-aerolink-74 (work in progress), November 2016.
- [RFC2119] Bradner, S., "Key words for use in RFCs to Indicate Requirement Levels", BCP 14, RFC 2119, DOI 10.17487/RFC2119, March 1997, <<http://www.rfc-editor.org/info/rfc2119>>.
- [RFC3753] Manner, J., Ed. and M. Kojo, Ed., "Mobility Related Terminology", RFC 3753, DOI 10.17487/RFC3753, June 2004, <<http://www.rfc-editor.org/info/rfc3753>>.
- [RFC5213] Gundavelli, S., Ed., Leung, K., Devarapalli, V., Chowdhury, K., and B. Patil, "Proxy Mobile IPv6", RFC 5213, DOI 10.17487/RFC5213, August 2008, <<http://www.rfc-editor.org/info/rfc5213>>.
- [RFC6275] Perkins, C., Ed., Johnson, D., and J. Arkko, "Mobility Support in IPv6", RFC 6275, DOI 10.17487/RFC6275, July 2011, <<http://www.rfc-editor.org/info/rfc6275>>.
- [RFC6459] Korhonen, J., Ed., Soininen, J., Patil, B., Savolainen, T., Bajko, G., and K. Iisakkila, "IPv6 in 3rd Generation Partnership Project (3GPP) Evolved Packet System (EPS)", RFC 6459, DOI 10.17487/RFC6459, January 2012, <<http://www.rfc-editor.org/info/rfc6459>>.
- [RFC7077] Krishnan, S., Gundavelli, S., Liebsch, M., Yokota, H., and J. Korhonen, "Update Notifications for Proxy Mobile IPv6", RFC 7077, DOI 10.17487/RFC7077, November 2013, <<http://www.rfc-editor.org/info/rfc7077>>.
- [RFC7333] Chan, H., Ed., Liu, D., Seite, P., Yokota, H., and J. Korhonen, "Requirements for Distributed Mobility Management", RFC 7333, DOI 10.17487/RFC7333, August 2014, <<http://www.rfc-editor.org/info/rfc7333>>.
- [RFC7429] Liu, D., Ed., Zuniga, JC., Ed., Seite, P., Chan, H., and CJ. Bernardos, "Distributed Mobility Management: Current Practices and Gap Analysis", RFC 7429, DOI 10.17487/RFC7429, January 2015, <<http://www.rfc-editor.org/info/rfc7429>>.

9.2. Informative References

[Paper-Distributed.Mobility]

Lee, J., Bonnin, J., Seite, P., and H. Chan, "Distributed IP Mobility Management from the Perspective of the IETF: Motivations, Requirements, Approaches, Comparison, and Challenges", IEEE Wireless Communications, October 2013.

[Paper-Distributed.Mobility.PMIP]

Chan, H., "Proxy Mobile IP with Distributed Mobility Anchors", Proceedings of GlobeCom Workshop on Seamless Wireless Mobility, December 2010.

[Paper-Distributed.Mobility.Review]

Chan, H., Yokota, H., Xie, J., Seite, P., and D. Liu, "Distributed and Dynamic Mobility Management in Mobile Internet: Current Approaches and Issues", February 2011.

Authors' Addresses

H. Anthony Chan (editor)
Huawei Technologies
5340 Legacy Dr. Building 3
Plano, TX 75024
USA

Email: h.a.chan@ieee.org

Xinpeng Wei
Huawei Technologies
Xin-Xi Rd. No. 3, Haidian District
Beijing, 100095
P. R. China

Email: weixinpeng@huawei.com

Jong-Hyouk Lee
Sangmyung University
31, Sangmyeongdae-gil, Dongnam-gu
Cheonan 31066
Republic of Korea

Email: jonghyouk@smu.ac.kr

Seil Jeon
Sungkyunkwan University
2066 Seobu-ro, Jangan-gu
Suwon, Gyeonggi-do
Republic of Korea

Email: seiljeon@skku.edu

Alexandre Petrescu
CEA, LIST
CEA Saclay
Gif-sur-Yvette, Ile-de-France 91190
France

Phone: +33169089223
Email: Alexandre.Petrescu@cea.fr

Fred L. Templin
Boeing Research and Technology
P.O. Box 3707
Seattle, WA 98124
USA

Email: fltemplin@acm.org