

Network Working Group
Internet-Draft
Intended status: Standards Track
Expires: December 31, 2015

S. Hares
Z. Li
L. Zhang
Huawei Technologies
June 29, 2015

Record NEXTHOP_PATH ATTRIBUTE for BGP
draft-hares-idr-nexthop-path-record-00

Abstract

In some BGP deployments, BGP next hops may use a set of tunnels or run across converged networks such as seamless MPLS. This document describes a new optional transitive path attribute, NEXTHOP_PATH ATTRIBUTE for BGP that records the next hop path which can be used by BGP network management to monitor and manage the BGP infrastructure via management interfaces (such as I2RS).

Requirements Language

The key words "MUST", "MUST NOT", "REQUIRED", "SHALL", "SHALL NOT", "SHOULD", "SHOULD NOT", "RECOMMENDED", "MAY", and "OPTIONAL" in this document are to be interpreted as described in RFC 2119 [RFC2119].

Status of This Memo

This Internet-Draft is submitted in full conformance with the provisions of BCP 78 and BCP 79.

Internet-Drafts are working documents of the Internet Engineering Task Force (IETF). Note that other groups may also distribute working documents as Internet-Drafts. The list of current Internet-Drafts is at <http://datatracker.ietf.org/drafts/current/>.

Internet-Drafts are draft documents valid for a maximum of six months and may be updated, replaced, or obsoleted by other documents at any time. It is inappropriate to use Internet-Drafts as reference material or to cite them other than as "work in progress."

This Internet-Draft will expire on December 31, 2015.

Copyright Notice

Copyright (c) 2015 IETF Trust and the persons identified as the document authors. All rights reserved.

This document is subject to BCP 78 and the IETF Trust's Legal Provisions Relating to IETF Documents (<http://trustee.ietf.org/license-info>) in effect on the date of publication of this document. Please review these documents carefully, as they describe your rights and restrictions with respect to this document. Code Components extracted from this document must include Simplified BSD License text as described in Section 4.e of the Trust Legal Provisions and are provided without warranty as described in the Simplified BSD License.

Table of Contents

- 1. Introduction 2
- 2. Definition of NEXTHOP_PATH_RECORD ATTRIBUTE 2
- 3. Process of NEXTHOP_PATH_RECORD ATTRIBUTE 4
 - 3.1. Creating and Modifying the NEXTHOP_PATH Attribute 4
 - 3.2. Error handling of NEXTHOP_PATH_RECORD Attribute 5
- 4. Deployment considerations 5
 - 4.1. BGP Tunnels 5
 - 4.2. Customized Best Path Selection 5
 - 4.3. Use in Seamless MPLS case with PE-RR 5
- 5. IANA Considerations 6
- 6. Security Considerations 6
- 7. References 7
 - 7.1. Normative References 7
 - 7.2. Informative References 7
- Authors' Addresses 8

1. Introduction

Network topologies may use BGP to become more highly interconnected via tunnels [I-D.rosen-idr-tunnel-encaps] or become interconnected carrier MPLS networks that [I-D.ietf-mpls-seamless-mpls] with multiple IGPs connected by IBGP into a single AS. In addition, BGP provides the ability to use provide additional paths [I-D.ietf-idr-add-paths], or use custom decision paths [I-D.ietf-idr-custom-decision] This document proposes a new path attribute that can record the next hop path of the route to help network management debugging of these new scenarios.

2. Definition of NEXTHOP_PATH_RECORD ATTRIBUTE

The NEXTHOP_PATH_RECORD ATTRIBUTE is an optional transitive BGP Path Attribute. The NEXTHOP_PATH_RECORD ATTRIBUTE type is defined as below (refer to [RFC4271]):

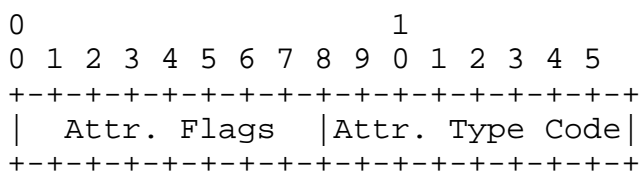

Figure 2 NEXTHOP_PATH_RECORD ATTRIBUTE Type definition

Attr. Flags

SHOULD be optional transitive

Attr. Type Code

SHOULD be allocated by IANA

NEXTHOP_PATH is composed of a sequence of next hop path segments. Each next hop path segment is represented by a triple <path segment type, path segment length, path segment value>. The format of the next hop path segment is shown in the figure 3.

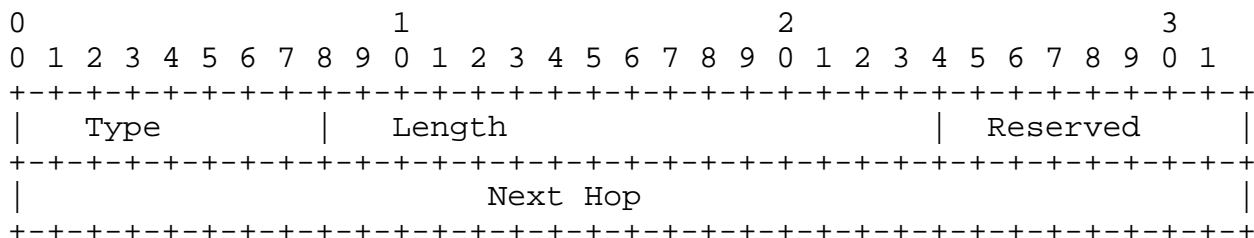

Figure 3 NH_SEQUENCE_V4 TLV

Type: A single octet encoding the TLV Type of path segment. The Type of NH_SEQUENCE_V4 is defined in this document, which needs to be allocated by IANA. A registry for other types of NH Path segments should be established by IANA.

Length: Two octets encoding the length in octets of the TLV, including the type and length fields. The length is encoded as an unsigned binary integer.

Reserved: A single octet that must be zero now.

NextHop: This contains a variable length of NextHops. For type NH_SEQUENCE_V4 the length of this value is four octets.

3. Process of NEXTHOP_PATH_RECORD ATTRIBUTE

The NEXTHOP_PATH attribute defined in this section is an optional transitive BGP Path Attribute as described in [RFC4271].

3.1. Creating and Modifying the NEXTHOP_PATH Attribute

When a BGP speaker distributes a route to its BGP peer within UPDATE message, the NEXTHOP_PATH ATTRIBUTE should be processed based on different route states:

1. If the route is originated in this BGP speaker
 - * If the NEXTHOP_PATH ATTRIBUTE is supported, the NEXTHOP_PATH ATTRIBUTE SHOULD be originated including the BGP speaker's own next hop address in a next hop path segment. In this case, the next hop address of the originating BGP speaker will be the only entry of the next hop path segment, and this path segment will be the only segment in NEXTHOP_PATH ATTRIBUTE.
 - * If the NEXTHOP_PATH_RECORD ATTRIBUTE is not supported, the route will be distributed without NEXTHOP_PATH ATTRIBUTE.
2. if the route is received from one BGP speaker's UPDATE message and and the NEXTHOP_PATH_RECORD is enabled and the nexthop is changed (via nexthop self or other means)
 - * If the NEXTHOP_PATH_RECORD ATTRIBUTE is NULL the NEXTHOP_PATH ATTRIBUTE SHOULD be originated including the BGP speaker's own next hop address in a next hop path segment. In this case, the next hop address of this BGP speaker will be the only entry to the next hop path segment, and this path segment will be the only segment in NEXTHOP_PATH ATTRIBUTE
 - * If the NEXTHOP_PATH_RECORD ATTRIBUTE is non-NULL and the local BGP speaker support NEXTHOP_PATH ATTRIBUTE, when the route is propagated to another IBGP speaker with next hop self (NHS), the BGP speaker MUST appends its own next hop address as the last one of the next hop path segments.
3. If the NEXTHOP_PATH_RECORD ATTRIBUTE is non-NULL and the local BGP speaker support NEXTHOP_PATH ATTRIBUTE, when the route is propagated to another BGP speaker without changing the next hop by the BGP speaker, the BGP speaker MUST NOT change the next hop path sequence.
4. If the BGP does not support the NEXTHOP_PATH record, it should keep the NEXTHOP_PATH RECORD unchanged.

3.2. Error handling of NEXTHOP_PATH_RECORD Attribute

If there are errors in the internal format of the NEXTHOP_PATH attribute, this attribute should simply be discarded as [I-D.ietf-idr-error-handling] specifies in section 3 as Attribute discard. The NEXTHOP_PATH_RECORD simply records nexthop information for monitoring.

4. Deployment considerations

Two deployment examples are given to demonstrate how the nexthop information can be deployed in existing BGP technologies to monitor and tune the BGP clouds (IBGP or EBGP) to provide better operation. maintenance. This attribute has records information.

4.1. BGP Tunnels

The [I-D.rosen-idr-tunnel-encaps] describes how BGP nexthop can be a set of tunnels. NEXTHOP_PATH_RECORD attribute can allow BGP routers to record when the BGP nexthop changes.

4.2. Customized Best Path Selection

The next_hop information gathered on an IBGP or EBP route could be used by off-line decision processing to select paths, and re-inserted as policy to affect the decision making via I2RS. The I2RS BGP use case draft [I-D.keyupate-idr-i2rs-bgp-usecases] describes this its section on customized best path selection (section 4.1) which uses the BGP feature [I-D.ietf-idr-custom-decision] to set a custom decision community.

4.3. Use in Seamless MPLS case with PE-RR

In a Seamless MPLS network [I-D.ietf-mpls-seamless-mpls], the Area Border Routers (ABRs) which run IBGP may act RR-clients or be part of RR mesh as described in section 5.1.7. Seamless MPLS places restrictions on the BGP NEXT_HOP to make Seamless MPLS work in the general case, but this may be tuned by tunnels or additional paths or other mechanism.

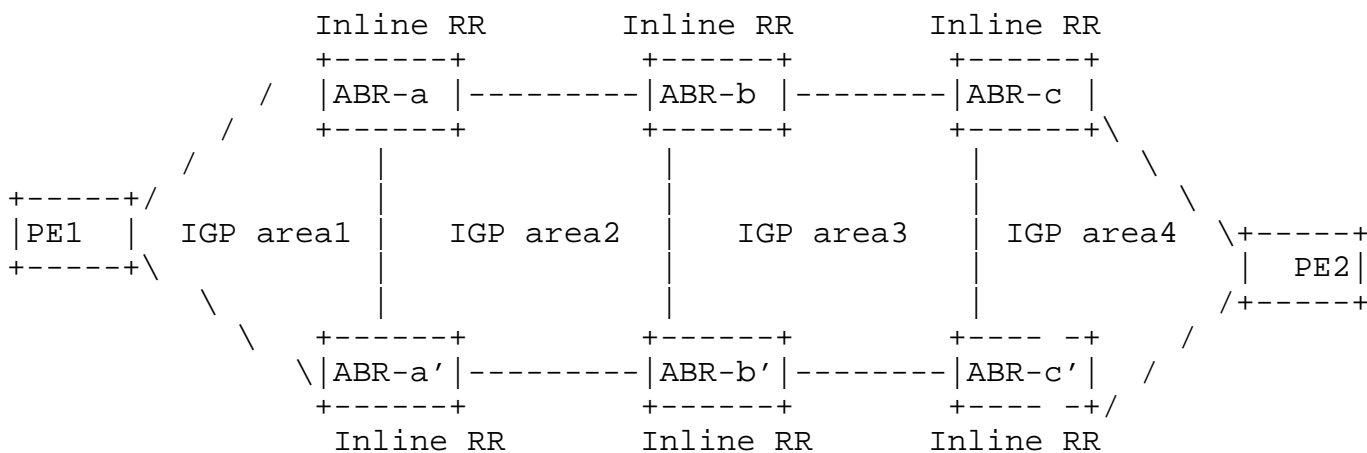

Figure 1 Seamless MPLS Network with Multiple IGP Areas

NEXTHOP_PATH_RECORD attribution may aid in monitoring paths in this complex paths that may consists of tunnels, customized paths, or Seamless MPLS topology.

5. IANA Considerations

IANA need to assign the codepoint in the "BGP Path Attributes" registry to the NEXTHOP_PATH_RECORD ATTRIBUTE.

IANA shall create a registry for "next hop path segment". The type field consists of a single octet, with possible values from 0 to 255. The allocation policy for this field is to be "Standards Action with Early Allocation". A new Type should be defined as "NH_SEQUENCE_V4".

6. Security Considerations

Note that, the NEXTHOP_PATH ATTRIBUTE is defined as a optional transitive BGP Path attribute. Both the IBGP and EBGP speaker can use this attribute. When an ASBR propagates the route receive from a IBGP peer to an EBGP peer, the NEXTHOP_PATH ATTRIBUTE will be distribute to the EBGP Speaker which may be controlled by other Service Provider. If the EBGP speaker can support the NEXTHOP_PATH ATTRIBUTE, it can parse the NEXTHOP_PATH ATTRIBUTE to get the inner network architecture of the other network.

BGP requires the use of TCP-MD5 TCP-MD5 [RFC2385] or TCP-AO [RFC5925]). Use of encryption will prevent unauthorized view of the NEXTHOP_PATH. For those not supporting the required TCP-MD5 or TCP-AO, the NEXTHOP_PATH ATTRIBUTE capability SHOULD disabled for specific BGP speaker to prevent this attack.

7. References

7.1. Normative References

- [I-D.ietf-idr-error-handling]
Chen, E., Scudder, J., Mohapatra, P., and K. Patel,
"Revised Error Handling for BGP UPDATE Messages", draft-
ietf-idr-error-handling-19 (work in progress), April 2015.
- [RFC2119] Bradner, S., "Key words for use in RFCs to Indicate
Requirement Levels", BCP 14, RFC 2119, March 1997.
- [RFC2385] Heffernan, A., "Protection of BGP Sessions via the TCP MD5
Signature Option", RFC 2385, August 1998.
- [RFC4271] Rekhter, Y., Li, T., and S. Hares, "A Border Gateway
Protocol 4 (BGP-4)", RFC 4271, January 2006.
- [RFC5925] Touch, J., Mankin, A., and R. Bonica, "The TCP
Authentication Option", RFC 5925, June 2010.

7.2. Informative References

- [I-D.ietf-idr-add-paths]
Walton, D., Retana, A., Chen, E., and J. Scudder,
"Advertisement of Multiple Paths in BGP", draft-ietf-idr-
add-paths-10 (work in progress), October 2014.
- [I-D.ietf-idr-custom-decision]
Retana, A. and R. White, "BGP Custom Decision Process",
draft-ietf-idr-custom-decision-06 (work in progress),
April 2015.
- [I-D.ietf-mpls-seamless-mpls]
Leymann, N., Decraene, B., Filsfils, C., Konstantynowicz,
M., and D. Steinberg, "Seamless MPLS Architecture", draft-
ietf-mpls-seamless-mpls-07 (work in progress), June 2014.
- [I-D.keyupate-idr-i2rs-bgp-usecases]
Patel, K., White, R., and S. Hares, "Use Cases for an
Interface to BGP Protocol", draft-keyupate-idr-i2rs-bgp-
usecases-00 (work in progress), May 2015.
- [I-D.rosen-idr-tunnel-encaps]
Rosen, E., Patel, K., and G. Velde, "Using the BGP Tunnel
Encapsulation Attribute without the BGP Encapsulation
SAFI", draft-rosen-idr-tunnel-encaps-00 (work in
progress), June 2015.

Authors' Addresses

Susan Hares
Huawei Technologies
7453 Hickory Hill
Saline, MI 48176
USA

Email: shares@ndzh.com

Zhenbin Li
Huawei Technologies
Huawei Bld., No.156 Beiqing Rd.
Beijing 100095
China

Email: lizhenbin@huawei.com

Li Zhang
Huawei Technologies
Huawei Bld., No.156 Beiqing Rd.
Beijing 100095
China

Email: monica.zhangli@huawei.com